

Hydraulic Cylinders ISO 6020/2

Catalog M1151

May, 2002

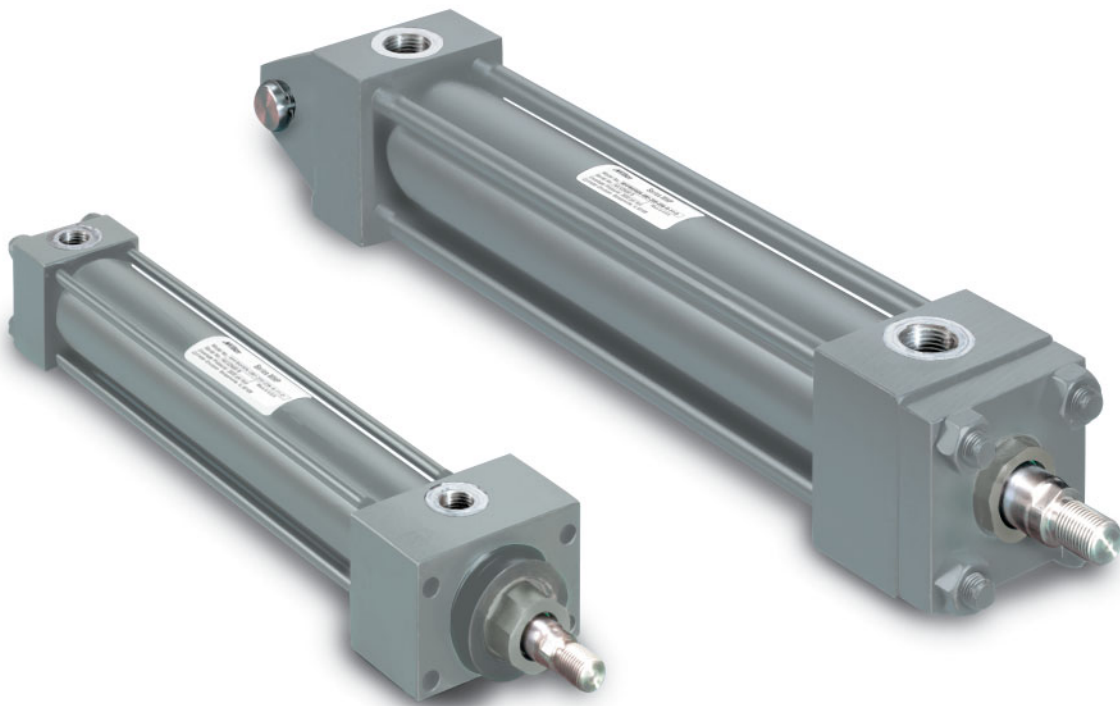

Up to 210 Bar
Bore Sizes 25mm through 200mm

A Series Cylinders
Up to 250 PSI – Permanently lubricated



Series A air cylinders are available in bore sizes from 1-1/2" through 20" and up to 250 PSI operating pressure. Standard NFPA dimensions and proven Miller design features.

IPA Series Cylinders
10 BAR



Up to 10 BAR pressure. Bore sizes 32mm through 200 mm. Meets and approved to GM pneumatic cylinder specifications CC-001. VDMA 24562 and ISO 6431 compatible.

AL4 Series Cylinders
250 PSI



Lightweight, non-lube pneumatic cylinder. Premium quality and economy in one. Bore sizes from 1-1/2" to 8".

H Series Cylinders
3000 PSI

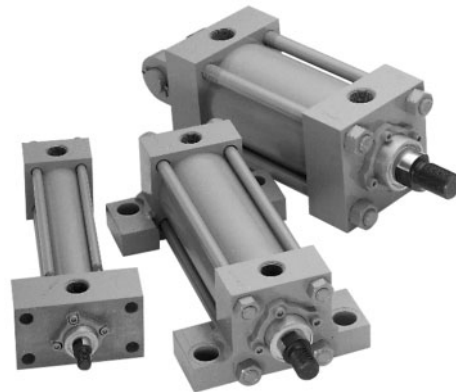

Miller's heavy-duty cylinder line for the most demanding hydraulic applications. Bore sizes from 1-1/2" to 20". Heavy-duty construction.

Warning

FAILURE OR IMPROPER SELECTION OR IMPROPER USE OF THE PRODUCTS AND/OR SYSTEMS DESCRIBED HEREIN OR RELATED ITEMS CAN CAUSE DEATH, PERSONAL INJURY AND PROPERTY DAMAGE.

This document and other information from The Company, its subsidiaries and authorized distributors provide product and/or system options for further investigation by users having technical expertise. It is important that you analyze all aspects of your application, including consequences of any failure and review the information concerning the product or system in the current product catalog. Due to the variety of operating conditions and applications for these products or systems, the user, through its own analysis and testing, is solely responsible for making the final selection of the products and systems and assuring that all performance, safety and warning requirements of the application are met.

The product described herein, including without limitation, product features, specifications, designs, availability and pricing, are subject to change by The Company and its subsidiaries at any time without notice.

Offer of Sale

The items described in this document are hereby offered for sale by The Company, its subsidiaries or its authorized distributors. This offer and its acceptance are governed by provisions stated on a separate page of this catalog in the document entitled "Offer of Sale".

Miller MHP Series Metric Hydraulic Cylinders

Contents	Page
Introduction	2
MHP Specifications	3
Mounting Styles	3
Design Features and Benefits	4, 5
Piston Rod End Data and Threads	7
Cylinder Dimensions	8
Double Rod Cylinders	12
Rod and Cap End Accessories	13
Mounting Information	16, 17
Theoretical Push & Pull Forces and Stroke Factors	18
Piston Rod Sizes, Stop Tubes and Long Stroke Cylinders	19
Cushioning	20-22
Pressure Limitations	22
Storage, Installation, Mounting and Troubleshooting	23
Ports, Locations and Piston Speeds	24, 25
Seals and Fluids, Weights	26
Optional Features	27
Replacement Parts and Service	28, 29
How to Order Cylinders	30, 31
Safety Guidelines	32

Index	Page
Accessories	13
Air Bleeds	4, 27
Cushioning	20-22
Cylinder Dimensions	8
Design Features	4, 5
Double Rod Cylinders	12
Forces – Push and Pull	18
Bushing Drains	5, 27
How to Order Cylinders	30
Model Numbers	31
Mounting Styles and Information	3, 16-17
Piston Rod End Data	7
Piston Rod Size Selection	19
Piston and Seal Types	5, 26
Ports – Standard and Oversize	24, 25
Pressure Ratings and Limitations	22
Repairs	28, 29
Seals and Fluids	26
Spare Parts	28
Speed Limitations	24
Stop Tubes	19
Stroke Adjusters	27
Stroke Factors	18
Stroke Tolerances	17
Thrust Keys	16
Water Service	26
Weights	26

Miller MHP Series Metric Hydraulic Cylinders

As a world leader in the design and manufacture of pneumatic and hydraulic cylinders, Miller Fluid Power introduces the MHP Series *metric* hydraulic cylinder. Miller Fluid Power's MHP Series cylinders are designed to meet the requirements of ISO 6020/2 (1991), 160 Bar Compact Series.

MHP Series cylinders may be used for working pressures up to 210 Bar.

Miller Fluid Power MHP Series cylinders are the true *world standard*, available all over the globe from worldwide manufacturing facilities.

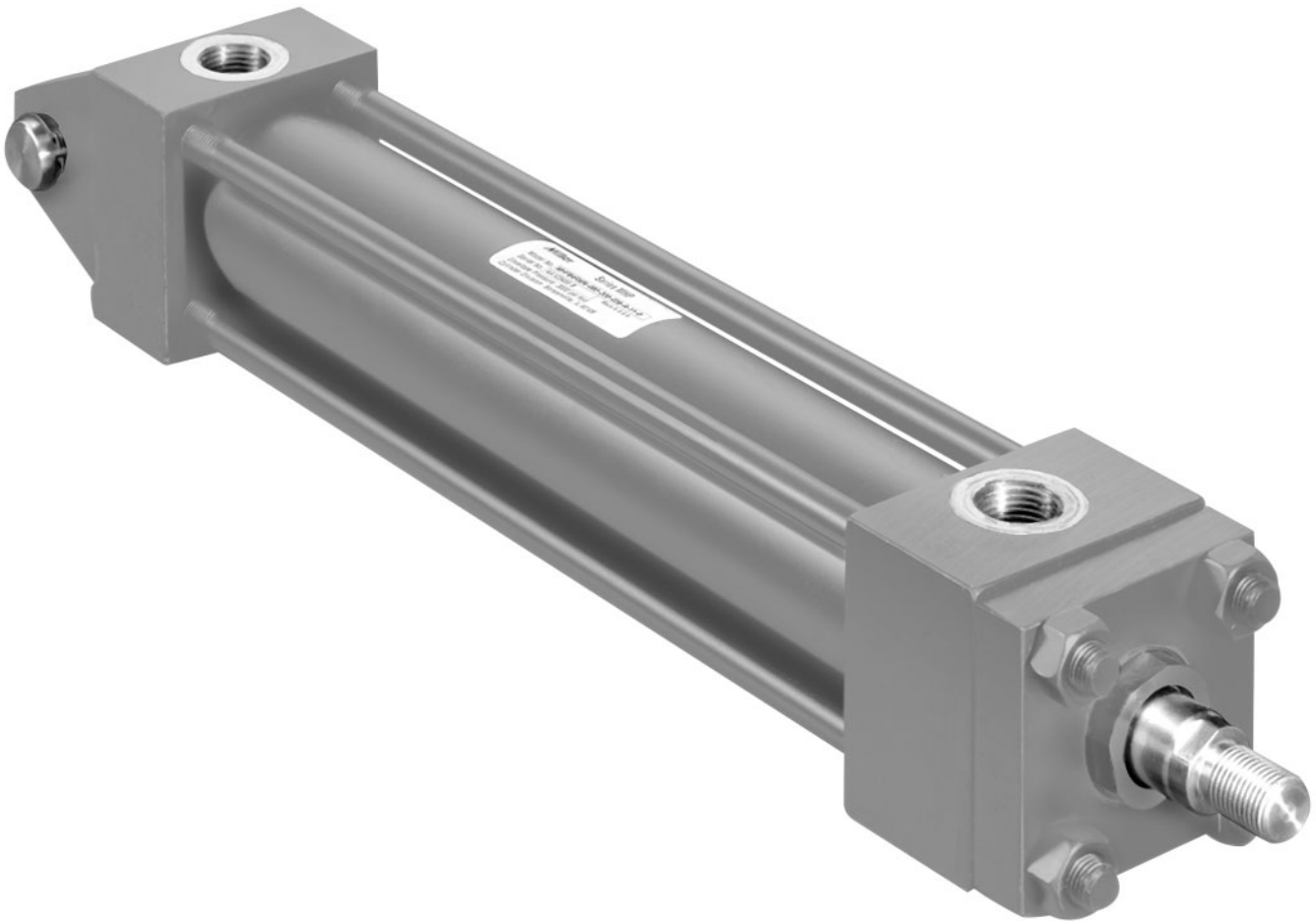

Introduction

The MHP Series cylinders described in this catalog are 160 bar Compact Series cylinders to ISO 6020/2 rated for use at working pressures up to 210 bar. They have been designed to satisfy the requirements of a wide range of industries in which cylinders to ISO standards are specified.

In addition to the standard cylinders featured in this catalog, MHP cylinders can be designed to suit customer requirements. Our engineers will be pleased to advise on unique designs to suit specific applications.

Miller MHP Series Metric Hydraulic Cylinders

Features, Specifications
and Mountings

MHP Series Standard Features and Specifications

- ISO 6020/2 mounting interchangeable
- 12 standard mounting styles
- Up to 3 rod sizes per bore
- Wide range of mounting accessories
- Up to 3 male and 3 female rod end threads per bore
- Bore sizes – 25mm to 200mm
- Strokes – available in any practical stroke length
- Working pressure up to 210 bar
- Piston rods – 12mm to 140mm
- Single and Double rod designs
- Cushions available at either or both ends
- Temperature Range – -20°C to 150°C depending on seal type
- Seal types to suit a wide variety of operating environments

In line with our policy of continuing product improvement, specifications in this catalog are subject to change.

Available Mountings

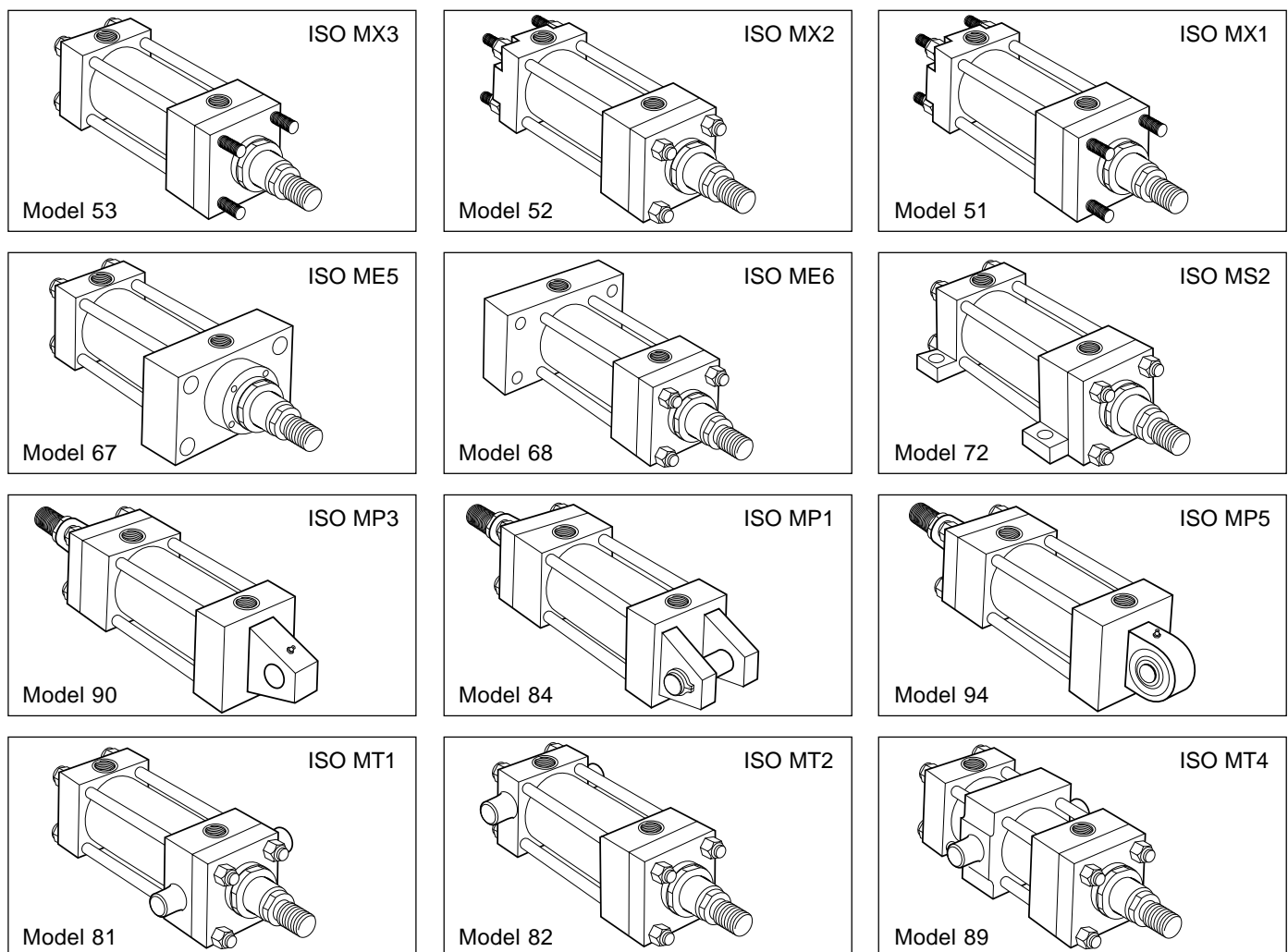

WARNING

FAILURE OR IMPROPER SELECTION OR IMPROPER USE OF THE PRODUCTS AND/OR SYSTEMS DESCRIBED HEREIN OR RELATED ITEMS CAN CAUSE DEATH, PERSONAL INJURY AND PROPERTY DAMAGE.

This document and other information from the Company, its subsidiaries and authorized distributors provide product and/or system options for further investigation by users having expertise. It is important that you analyze all aspects of your application, including consequences of any failure and review the information concerning the product or system in the current product catalog. Due to the variety of operating conditions and applications for these products or systems, the user, through its own analysis and testing, is solely responsible for making the final selection of the products and systems and assuring that all performance, safety and warning requirements of the application are met.

The products described herein, including without limitation, product features, specifications, designs, availability and pricing, are subject to change by the Company and its related companies at any time without notice.

Miller MHP Series Metric Hydraulic Cylinders

Design Features and Benefits

Here is the inside story of why the MHP Series is your best choice in a metric heavy duty hydraulic cylinder...

1 Piston Rod

Rod seal life is maximized by manufacturing piston rods from precision ground, high tensile carbon alloy steel, hard chrome plated and polished to 0.2µm max. Piston rods are induction case hardened to Rockwell C54 minimum before chrome plating, resulting in a dent-resistant surface.

2 Bushing

Continuous lubrication, and therefore longer bushing life, are provided by the long iron bearing surface inboard of the primary seal. The bushing, complete with rod seals, can easily be removed without dismantling the cylinder and without special tools, so servicing is quicker – and therefore more economical.

3 Rod Seals

The Tuff Seal primary seal has a series of sealing edges which take over successively as pressure increases, providing efficient sealing under all operating conditions. On the return stroke the serrations act as a check valve, allowing the oil adhering to the rod to pass back into the cylinder.

The double lip wiperseal acts as a secondary seal, trapping excess lubricating film in the chamber between the wiper and lip seals. Its outer lip prevents the ingress of dirt into the cylinder, extending the life of gland and seals.

The Tuff Seal is manufactured from an enhanced polyurethane, giving efficient retention of pressurized fluid and long service life.

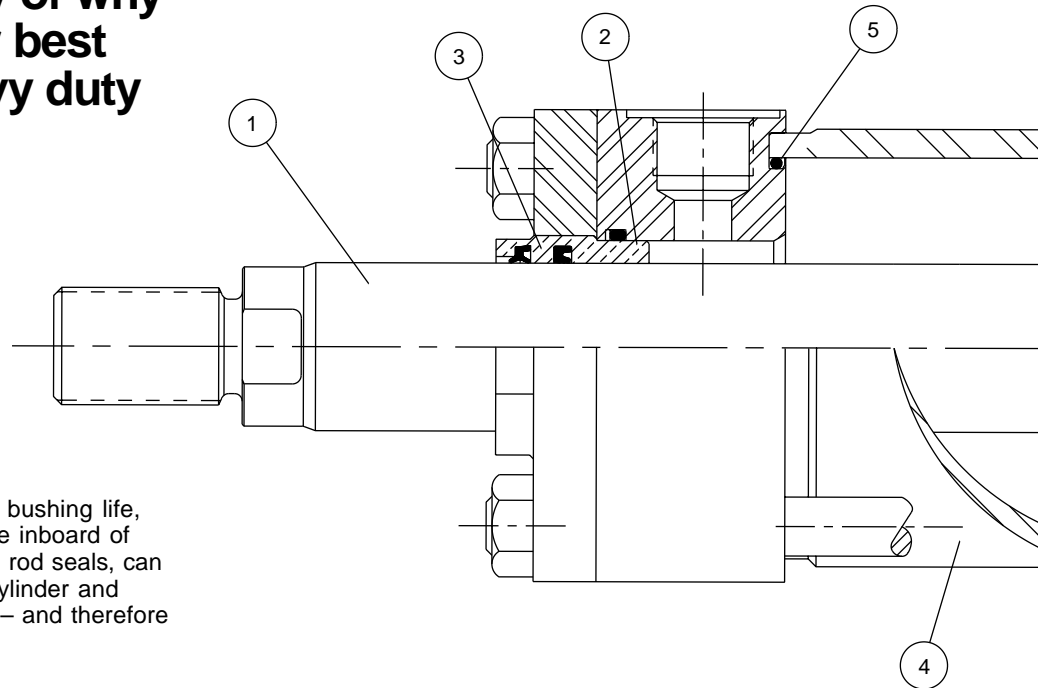

4 Cylinder Tube

Strict quality control standards and precision manufacture ensure that all tubes meet rigid standards of straightness, roundness and surface finish. The steel tubing is surface finished to minimize internal friction and prolong seal life.

5 Cylinder Tube End Seals

To make sure that the cylinder tube remains leaktight, even under pressure shock conditions, Miller Fluid Power utilizes pressure-energized tube end seals.

6 One-Piece Piston

A long thread engagement secures the piston to the piston rod and, as an added safety feature, pistons are secured by an anaerobic adhesive.

Optional

Air Bleeds

Available as an option at both ends, the air bleeds are recessed into the head and cap.

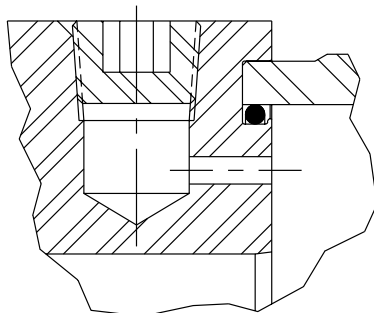

Servo Cylinders

Servo cylinders permit fine control of acceleration, velocity and position in applications where very low friction and an absence of stick-slip are required. They may be used in conjunction with integral or external transducers. Servo cylinders combine low friction piston and bushing seals with specially selected tubes and rods. For low-friction applications – consult factory.

Seal Classes

To accommodate the many types of fluids and the varying temperature ranges used in industry, Miller Fluid Power offers a range of rod bushing, piston and tube seals.

Miller MHP Series Metric Hydraulic Cylinders

Design Features and Benefits

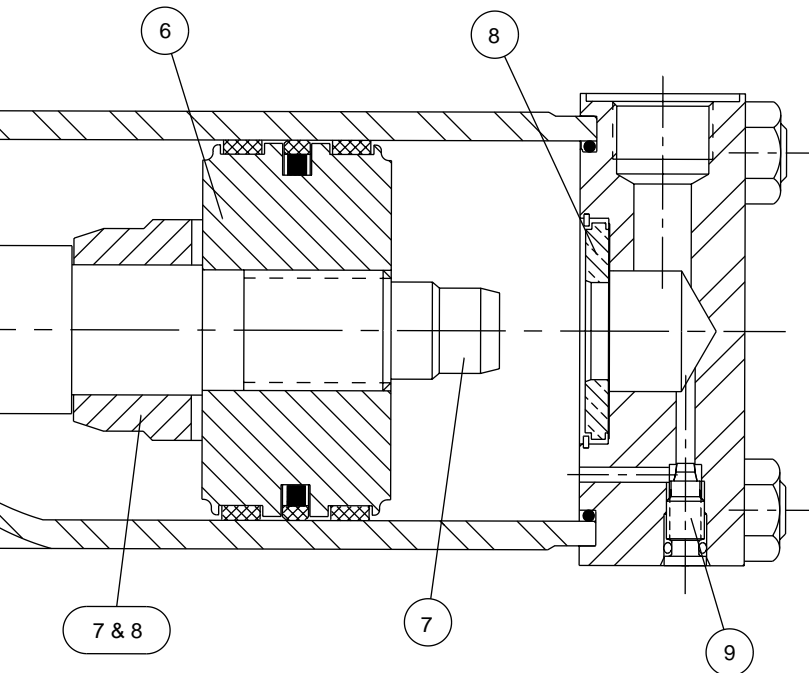

7 Cushioning

Progressive deceleration is available by using profiled cushions at the head and cap. The head end cushion is self aligning, while the polished cap end plunger is an integral part of the piston rod.

8 Floating Cushion Bushings and Plungers

Closer tolerances – and therefore more effective cushioning – are permitted by the use of a floating cushion plunger at the head end of the cylinder, and a floating cushion bushing at the cap end. A slotted cushion plunger on the head end, and the floating bronze cushion bushing in the cap, provide minimum fluid restriction at the start of the return stroke. This allows full pressure to be applied over the entire area of the piston, providing full power and fast cycle times.

Bushing Drains

The accumulation of fluid behind the bushing wiperseal of long stroke cylinders, or cylinders with constant back pressure, can be relieved by specifying the option of a bushing drain. A port between the wiperseal and primary seal allows fluid to be piped back to a reservoir. By fitting a transparent tube between the port and the reservoir, fluid loss from concealed or inaccessible cylinders can be monitored to provide an early indication of the need for bushing servicing.

9 Cushion Adjustment

Needle valves are provided at both ends of the cylinder for precise cushion adjustment. 63mm bores and smaller contain the cartridge cushion assembly shown below.

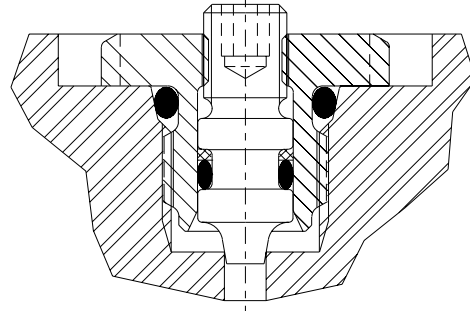

10 Piston Seals

Miller's B style piston is a single seal design which incorporates two wear strips. This design provides smooth operation, long bearing life, and high load carrying capacity.

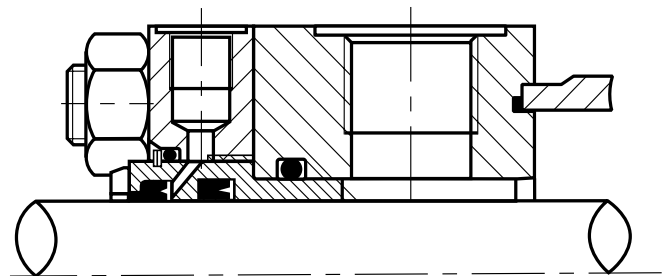
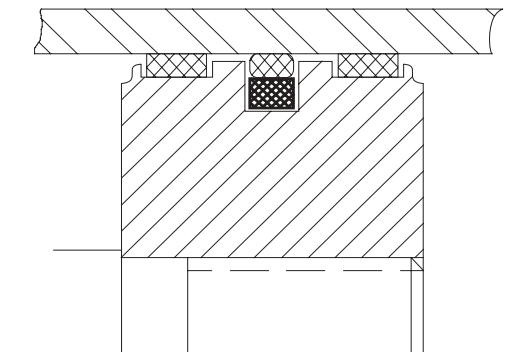

Miller MHP Series Metric Hydraulic Cylinders

ISO Cylinder Mounting Styles and Where to Find Them

The standard range of Miller Fluid Power MHP Series cylinders comprises 12 ISO mounting styles to suit the majority of applications. General guidance for the selection of ISO cylinders is given below, with dimensional information about each mounting style shown on the following pages. Application-specific mounting information is shown in the mounting information section of this catalog.

Extended Tie Rods

Cylinders with 53, 52 and 51 mountings are suitable for straight line force transfer applications, and are particularly useful where space is limited. For compression (push) applications, cap end tie rod mountings are most appropriate; where the major load places the piston rod in tension (pull applications), head end mounting styles should be specified. Cylinders with tie rods extended at both ends may be attached to the machine member from either end, allowing the free end of the cylinder to support a bracket or switch.

Flange Mounted Cylinders

These cylinders are also suitable for use on straight line force transfer applications. Two flange mounting styles are available, offering either a head flange (67) or a cap flange (68). Selection of the correct flange mounting style depends on whether the major force applied to the load will result in compression (push) or tension (pull) stresses on the piston rod. For compression-type applications, the cap mounting style is most appropriate; where the major load places the piston rod in tension, a head mounting should be specified.

Foot Mounted Cylinders

Model 72, foot mounted cylinders, do not absorb forces on their centerline. As a result, the application of force by the cylinder produces a moment which attempts to rotate the cylinder about its mounting bolts. It is important, therefore, that the cylinder should be firmly secured to the mounting surface and that the load should be effectively guided to avoid side loads being applied to rod gland and piston bearings. A thrust key modification may be specified to provide positive cylinder location.

Pivot Mountings

Cylinders with pivot mountings, which absorb forces on their centerlines, should be used where the machine member to be moved travels in a curved path. Pivot mountings may be used for tension (pull) or compression (push) applications. Cylinders using a fixed clevis, models 84 and 90, may be used if the curved path of the piston rod travel is in a single plane; for applications where the piston rod will travel in a path on either side of the true plane of motion, a spherical bearing mounting 94 is recommended.

Trunnion Mounted Cylinders

These cylinders, models 81, 82 and 89, are designed to absorb force on their centerlines. They are suitable for tension (pull) or compression (push) applications, and may be used where the machine member to be moved travels in a curved path in a single plane. Trunnion pins are designed for shear loads only and should be subjected to minimum bending stresses.

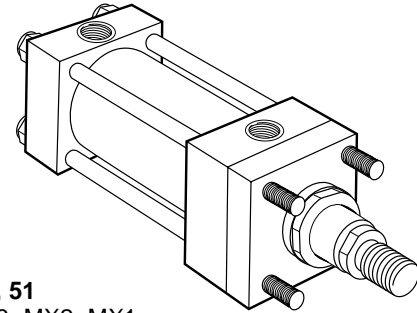

Models 53, 52, 51
ISO Styles MX3, MX2, MX1

53

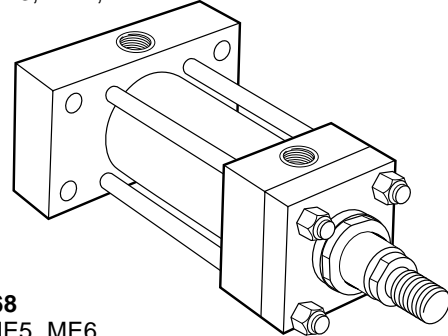

Models 67, 68
ISO Styles ME5, ME6

68

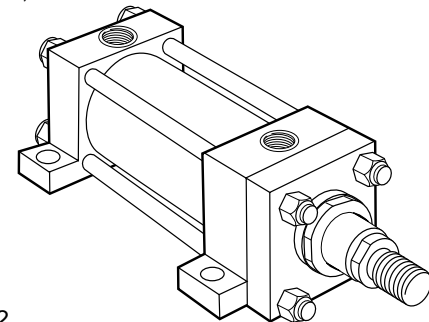

Model 72
ISO Style MS2

72

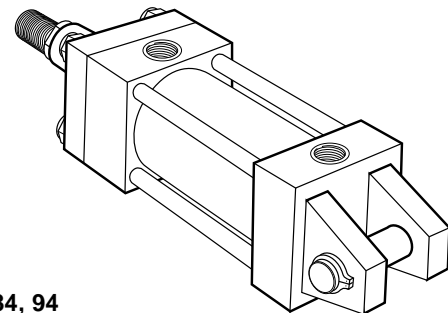

Models 90, 84, 94
ISO Styles MP3, MP1, MP5

84

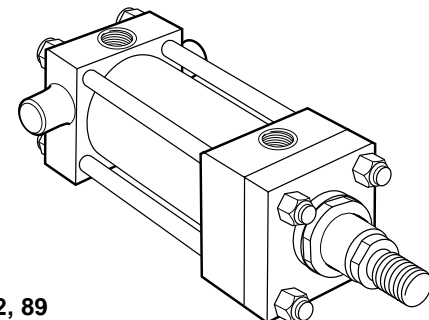

Models 81, 82, 89
ISO Styles MT1, MT2, MT4

82

Miller MHP Series Metric Hydraulic Cylinders

Piston Rod End Data
and Threads

Thread Styles M & S – All Except 67 Mount

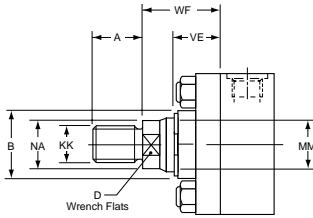

Thread Styles M & S – 67 Mount

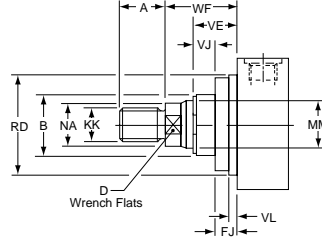

Thread Style T – All Except 67 Mount

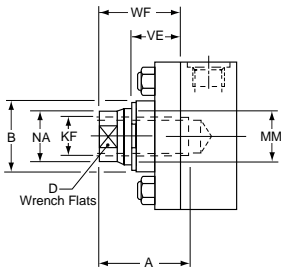

Thread Style T – 67 Mount

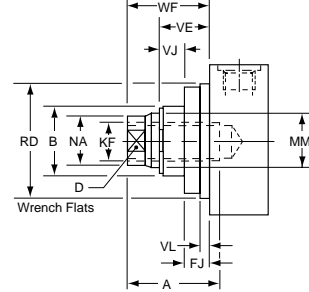

Thread Styles M & S

The smallest diameter rod end thread for each bore size is designated Style M. When the same rod end thread is supplied with an oversize rod it is designated Style S.

Thread Style T – Short Stroke Cylinders

Style T (female) rod ends should not be used on 160mm or 200mm bore cylinders with a stroke of 50mm or less. Please consult the factory, with details of the application.

Thread Style X

Non-standard piston rod ends are designated 'Style X'. A dimensional sketch or description should accompany the order. Please specify dimensions KK or KF, A, rod stand out WF and thread type.

25 & 32mm Bore Cylinders

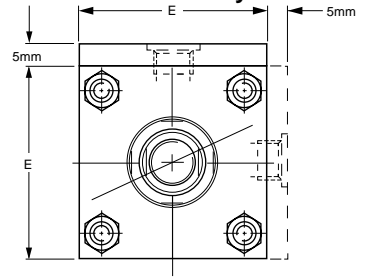

5mm extra height applies to port face at head end only.

Bushing Retainer – 160 and 200mm Bore

On all 160mm and 200mm bore ISO mounting styles except 53 and 51, the bushing retainer is separately bolted to the head, as shown.

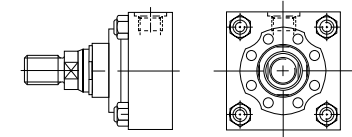

Piston Rod End Dimensions

Bore φ	MM Rod φ	Style M		Style S		Style T		B _{f9}	D	NA	VE	WF	67 Mount Only				
		KK	A	KK	A	KF	A						VL min	RD f8	VJ	FJ	
25	12	M10x1.25	14	-	-	M8x1	14	24	10	11	16	25	3	38	6	10	
	18	M14x1.5	18	M10x1.25	14	M12x1.25	18	30	15	17	16						
32	14	M12x1.25	16	-	-	M10x1.25	16	26	12	13	22	35	3	42	12	10	
	22	M16x1.5	22	M12x1.25	16	M16x1.5	22	34	18	21	22						
40	18	M14x1.5	18	-	-	M12x1.25	18	30	15	17	16	35	3	62	6	10	
	28	M20x1.5	28	M14x1.5	18	M20x1.5	28	42	22	26	22				12		
50	22	M16x1.5	22	-	-	M16x1.5	22	34	18	21	22	41	4	74	6	16	
	36	M27x2	36	M16x1.5	22	M27x2	36	50	30	34	25				9		
63	28	M20x1.5	28	-	-	M20x1.5	28	42	22	26	22	48	4	75	6	16	
	45	M33x2	45	M20x1.5	28	M33x2	45	60	39	43	29				13		
80	36	M27x2	36	-	-	M27x2	36	50	30	34	25	51	4	82	5	20	
	56	M42x2	56	M27x2	36	M42x2	56	72	48	54	29				9		
100	45	M33x2	45	-	-	M33x2	45	60	39	43	29	57	5	92	7	22	
	70	M48x2	63	M33x2	45	M48x2	63	88	62	68	32				10		
125	56	M42x2	56	-	-	M42x2	56	72	48	54	29	57	5	105	9	20	
	90	M64x3	85	M42x2	56	M64x3	85	108	80	88	32				7		
160	70	M48x2	63	-	-	M48x2	63	88	62	68	32	57	5	125	10	22	
	110	M80x3	95	M48x2	63	M80x3	95	133	100	108	32				25		
200	90	M64x3	85	-	-	M64x3	85	108	80	88	32	57	5	150	10	22	
	140	M100x3	112	M64x3	85	M100x3	112	163	128	138	32				7		
	110	M80x3	95	M64x3	85	M80x3	95	133	100	108	32						25

All dimensions are in millimeters unless otherwise stated.

Miller MHP Series Metric Hydraulic Cylinders

Extended Tie Rod Mountings

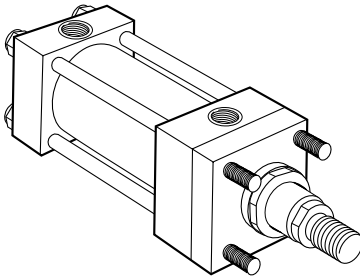

Model 53
Tie Rods Extended Head End
(ISO Style MX3)

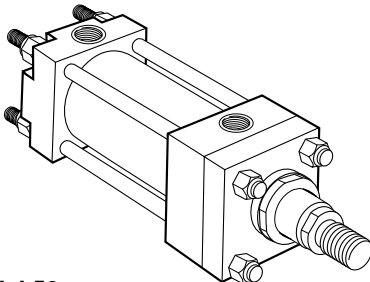
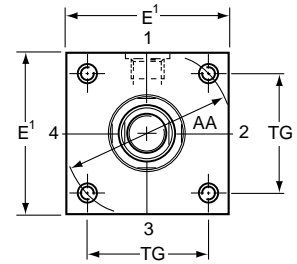
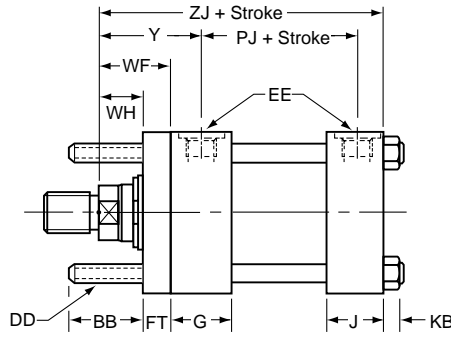

Model 52
Tie Rods Extended Cap End
(ISO Style MX2)

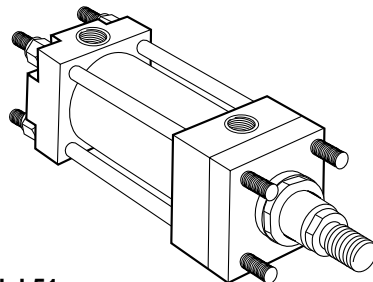
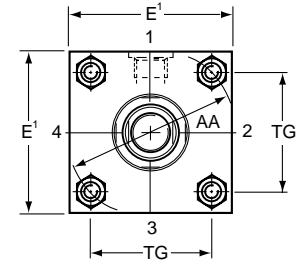
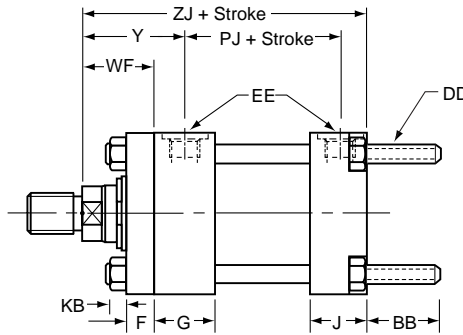

Model 51
Tie Rods Extended Both Ends
(ISO Style MX1)

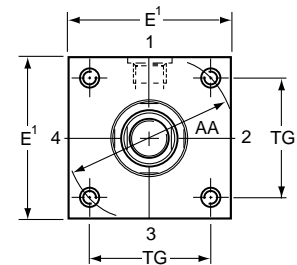
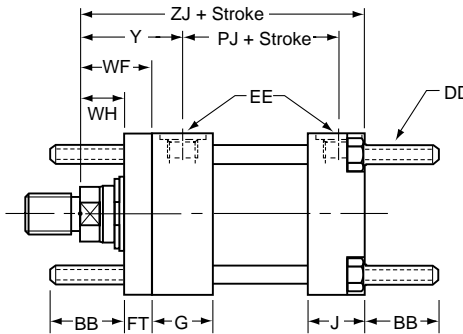

¹Head depth increased by 5mm to accommodate port on 25mm and 32mm bore cylinders – see piston rod end data page.

Dimensions – 53, 52, 51 See also Rod End Dimensions and Mounting Information

Bore φ	AA	BB	DD	E	EE BSP/G inches	F	FT	G	J	KB	TG	WF	WH	Y	+ Stroke	
															PJ	ZJ
25	40	19	M5x0.8	40 ¹	1/4	10	10	40	25	4	28.3	25	15	50	53	114
32	47	24	M6x1	45 ¹	1/4	10	10	40	25	5	33.2	35	25	60	56	128
40	59	35	M8x1	63	3/8	10	10	45	38	6.5	41.7	35	25	62	73	153
50	74	46	M12x1.25	75	1/2	16	16	45	38	10	52.3	41	25	67	74	159
63	91	46	M12x1.25	90	1/2	16	16	45	38	10	64.3	48	32	71	80	168
80	117	59	M16x1.5	115	3/4	20	20	50	45	13	82.7	51	31	77	93	190
100	137	59	M16x1.5	130	3/4	22	22	50	45	13	96.9	57	35	82	101	203
125	178	81	M22x1.5	165	1	22	22	58	58	18	125.9	57	35	86	117	232
160	219	92	M27x2	205	1	25	25	58	58	22	154.9	57	32	86	130	245
200	269	115	M30x2	245	1-1/4	25	25	76	76	24	190.2	57	32	98	165	299

All dimensions are in millimeters unless otherwise stated.

Miller MHP Series Metric Hydraulic Cylinders

Flange and
Side Lug Mountings

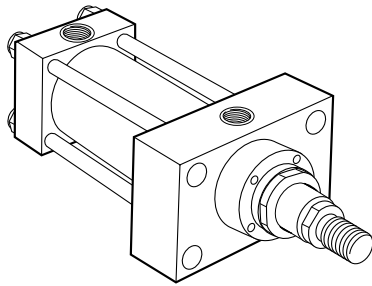

Model 67
Head Rectangular Flange
(ISO Style ME5)

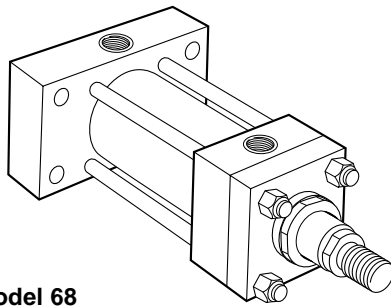
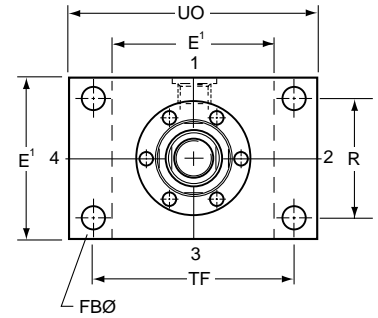
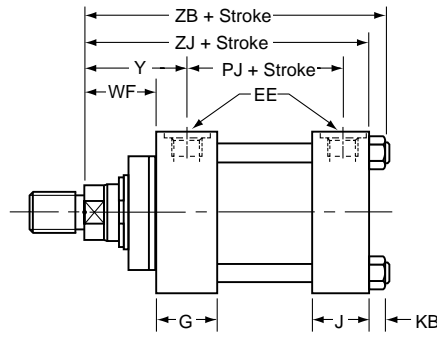

Model 68
Cap Rectangular Flange
(ISO Style ME6)

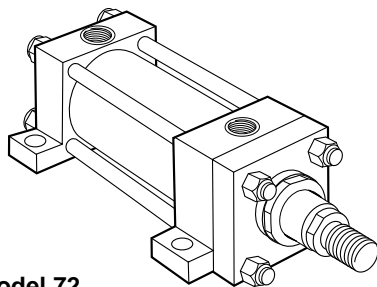
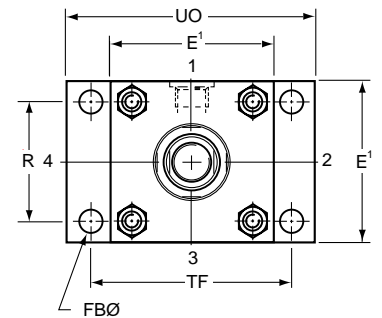
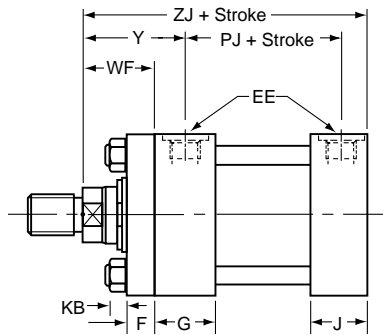

Model 72
Side Lugs
(ISO Style MS2)

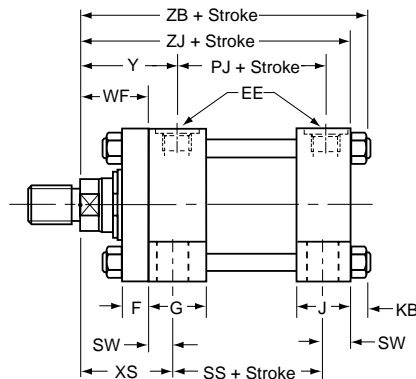

A thrust key may be used with this mounting style.

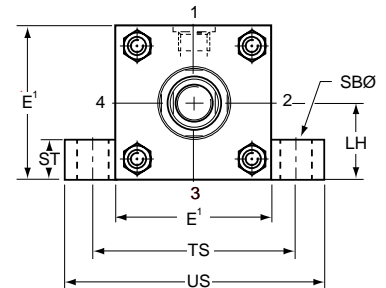

¹Head depth increased by 5mm to accommodate port on 25mm and 32mm bore cylinders, except Model 67 in port positions 2 and 4 – see port information.

Dimensions – 67, 68 & 72 See also Rod End Dimensions and Mounting Information.

Bore φ	E	EE BSP/G inches	F	FB	G	J	KB	LH	R	SB	ST	SW	TF	TS	UO	US	WF	XS	Y	+ Stroke			
																				PJ	SS	ZB	ZJ
25	40 ¹	1/4	10	5.5	40	25	4	19	27	6.6	8.5	8	51	54	65	72	25	33	50	53	73	121	114
32	45 ¹	1/4	10	6.6	40	25	5	22	33	9	12.5	10	58	63	70	84	35	45	60	56	73	137	128
40	63	3/8	10	11	45	38	6.5	31	41	11	12.5	10	87	83	110	103	35	45	62	73	98	166	153
50	75	1/2	16	14	45	38	10	37	52	14	19	13	105	102	130	127	41	54	67	74	92	176	159
63	90	1/2	16	14	45	38	10	44	65	18	26	17	117	124	145	161	48	65	71	80	86	185	168
80	115	3/4	20	18	50	45	13	57	83	18	26	17	149	149	180	186	51	68	77	93	105	212	190
100	130	3/4	22	18	50	45	13	63	97	26	32	22	162	172	200	216	57	79	82	101	102	225	203
125	165	1	22	22	58	58	18	82	126	26	32	22	208	210	250	254	57	79	86	117	131	260	232
160	205	1	25	26	58	58	22	101	155	33	38	29	253	260	300	318	57	86	86	130	130	279	245
200	245	1-1/4	25	33	76	76	24	122	190	39	44	35	300	311	360	381	57	92	98	165	172	336	299

All dimensions are in millimeters unless otherwise stated.

Miller MHP Series Metric Hydraulic Cylinders

Pivot Mountings

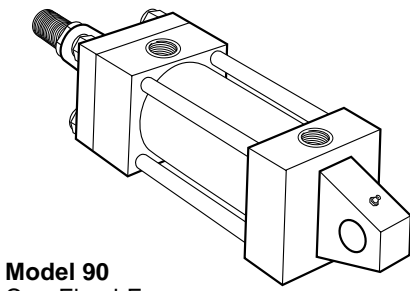

Model 90
Cap Fixed Eye
(ISO Style MP3)

Pivot pin not supplied

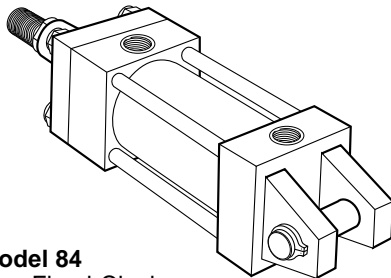
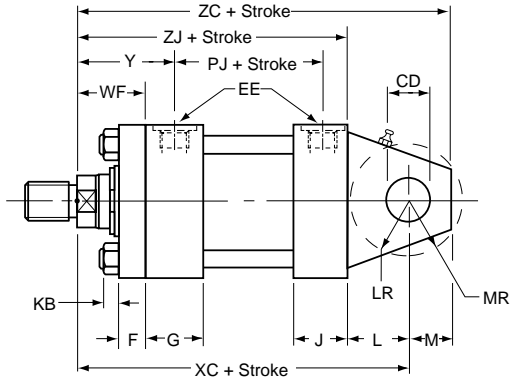
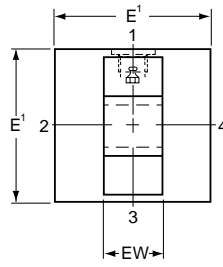

Model 84
Cap Fixed Clevis
(ISO Style MP1)

Supplied complete with pivot pin

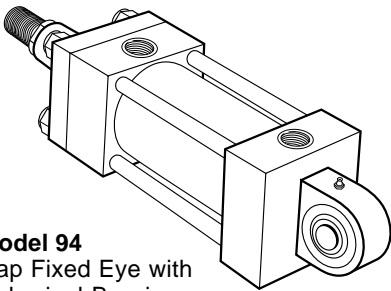
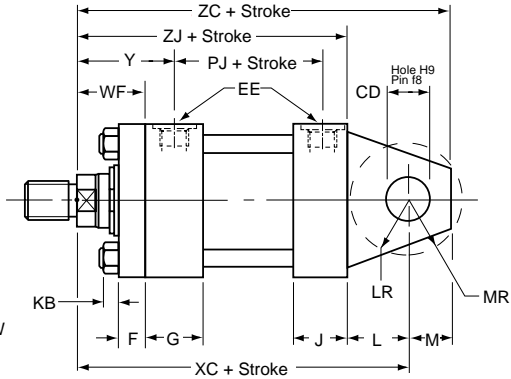
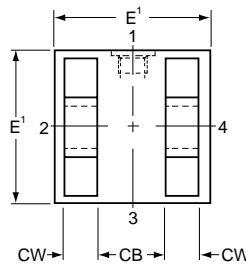

Model 94
Cap Fixed Eye with
Spherical Bearing
(ISO Style MP5)

Pivot pin not supplied

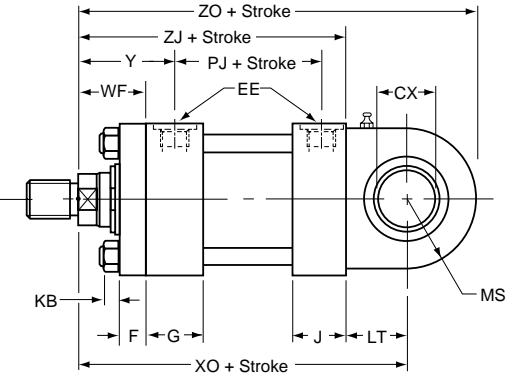
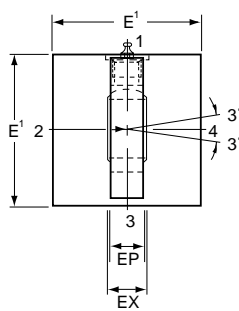

¹Head depth increased by 5mm to accommodate port on 25mm and 32mm bore cylinders – see piston rod end data page.

Dimensions – 90, 84 & 94 See also Rod End Dimensions and Mounting Information.

Bore φ	CB A16	CD H9	CW	CX	E	EE BSP/G inches	EP	EW h14	EX	F	G	J	KB	L	LR	LT	M	MR	MS max	WF	Y	+ Stroke					
																						PJ	XC	XO	ZC	ZJ	ZO
25	12	10	6	12-0.008	40 ¹	1/4	8	12	10	10	40	25	4	13	12	16	10	12	20	25	50	53	127	130	137	114	150
32	16	12	8	16-0.008	45 ¹	1/4	11	16	14	10	40	25	5	19	17	20	12	15	22.5	35	60	56	147	148	159	128	170.5
40	20	14	10	20-0.012	63	3/8	13	20	16	10	45	38	6.5	19	17	25	14	16	29	35	62	73	172	178	186	153	207
50	30	20	15	25-0.012	76	1/2	17	30	20	16	45	38	10	32	29	31	20	25	33	41	67	74	191	190	211	159	223
63	30	20	15	30-0.012	90	1/2	19	30	22	16	45	38	10	32	29	38	20	25	40	48	71	80	200	206	220	168	246
80	40	28	20	40-0.012	115	3/4	23	40	28	20	50	45	13	39	34	48	28	34	50	51	77	93	229	238	257	190	288
100	50	36	25	50-0.012	130	3/4	30	50	35	22	50	45	13	54	50	58	36	44	62	57	82	101	257	261	293	203	323
125	60	45	30	60-0.015	165	1	38	60	44	22	58	58	18	57	53	72	45	53	80	57	86	117	289	304	334	232	384
160	70	56	35	80-0.015	205	1	47	70	55	25	58	58	22	63	59	92	59	59	100	57	86	130	308	337	367	245	437
200	80	70	40	100-0.020	245	1-1/4	57	80	70	25	76	76	24	82	78	116	70	76	120	57	98	165	381	415	451	299	535

All dimensions are in millimeters unless otherwise stated.

Miller MHP Series Metric Hydraulic Cylinders

Trunnion Mountings

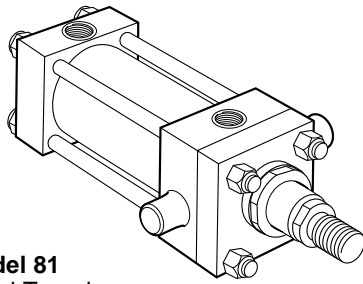

Model 81
Head Trunnion
(ISO Style MT1)

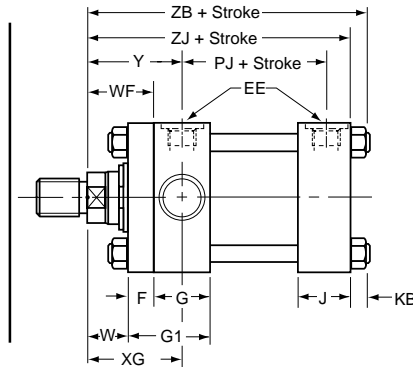

Notes:

A one-piece head and retainer is used on 100mm-200mm bore sizes – G1 dimension. On 160 and 200mm bores, the bolted bushing is recessed, with tie rods screwed into the head.

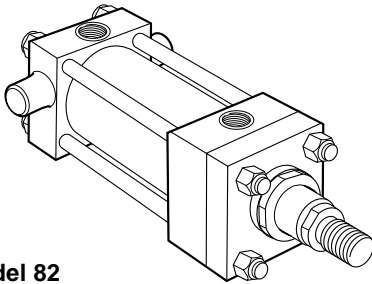
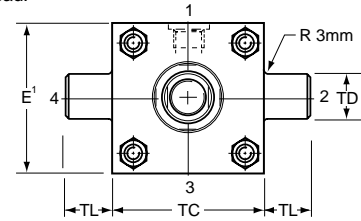

Model 82
Cap Trunnion
(ISO Style MT2)

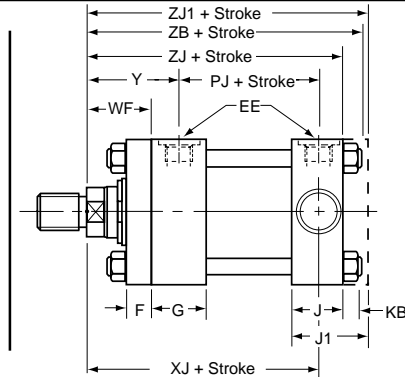

Note:

On 100-200mm bore cylinders, dimension J becomes J1. ZJ1 replaces ZB, and tie rods are screwed directly into the cap.

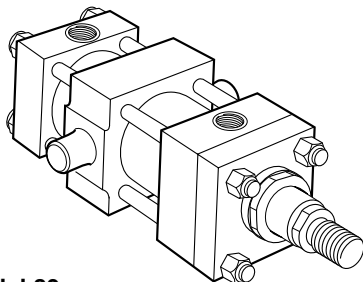
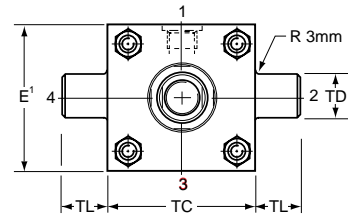

Model 89
Intermediate Trunnion
(ISO Style MT4)

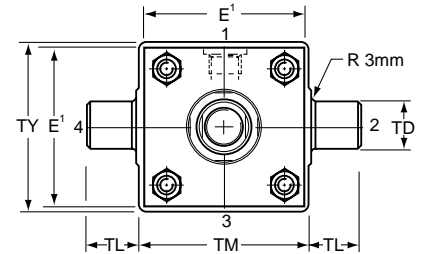
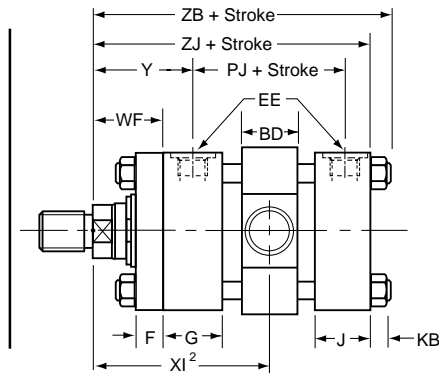

¹Head depth increased by 5mm to accommodate port on 25mm and 32mm bore cylinders – see piston rod end data page.

²Dimensions to be specified by customer. See table below for minimum XI dimension.

Dimensions – 81, 82 & 89 See also Rod End Dimensions and Mounting Information.

Bore φ	BD	E	EE BSP/G inches	F	G	G1	J	J1	KB	TC	TD f8	TL	TM	TY	W	WF	XG	Y	+ Stroke					Model 89 min stroke	Min XI dim'n
																			PJ	XJ	ZJ	ZJ1	ZB		
25	20	40 ¹	1/4	10	40	-	25	-	4	38	12	10	48	45	-	25	44	50	53	101	114	-	121	10	78
32	25	45 ¹	1/4	10	40	-	25	-	5	44	16	12	55	54	-	35	54	60	56	115	128	-	137	10	90
40	30	63	3/8	10	45	-	38	-	6.5	63	20	16	76	76	-	35	57	62	73	134	153	-	166	15	97
50	40	76	1/2	16	45	-	38	-	10	76	25	20	89	89	-	41	64	67	74	140	159	-	176	15	107
63	40	90	1/2	16	45	-	38	-	10	89	32	25	100	95	-	48	70	71	80	149	168	-	185	15	114
80	50	115	3/4	20	50	-	45	50	13	114	40	32	127	127	-	51	76	77	93	168	190	194	212	20	127
100	60	130	3/4	22	50	72	45	58	13	127	50	40	140	140	35	57	71	82	101	187	203	216	225	20	138
125	73	165	1	22	58	80	58	71	18	165	63	50	178	178	35	57	75	86	117	209	232	245	260	25	153
160	90	205	1	25	58	88	58	88	22	203	80	63	215	216	32	57	75	86	130	230	245	275	279	30	161
200	110	245	1-1/4	25	76	108	76	108	24	241	100	80	279	280	32	57	85	98	165	276	299	330	336	30	190

All dimensions are in millimeters unless otherwise stated.

Miller MHP Series Metric Hydraulic Cylinders

Double Rod Cylinders

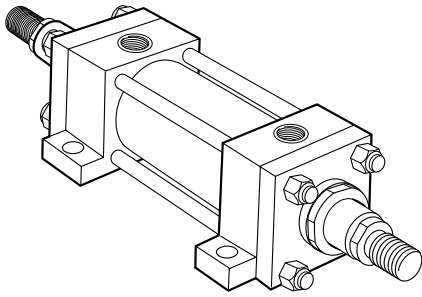

Double Rod Cylinder

Available with Models 53, 51, 67, 72, 81, 89 (Model 72 illustrated)

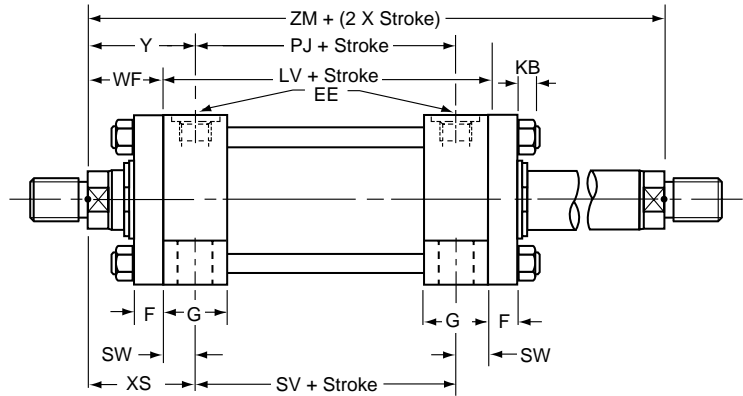

Mounting Styles and Codes

Double rod cylinders are denoted by a 'D' in the MHP cylinder model code.

Dimensions

To obtain dimensional information for double rod cylinders, first select the desired mounting style by referring to the corresponding single rod model. Dimensions for the appropriate single rod model should be supplemented by those from the table opposite to provide a full set of dimensions.

Minimum Stroke Length – Style T Rod End

Where a style T (female) piston rod end is required on a double rod cylinder with a stroke of 80mm or less, and a bore of 80mm or above, please consult the factory.

Cushioning

Double rod cylinders can be supplied with cushions at either or both ends. Cushioning requirements should be specified by inserting the proper letter in the order number. See how-to-order page of this catalog.

Double Rod Cylinders

For double rod cylinders, specify rod diameter and rod end symbols for both piston rods. See how-to-order page for instructions.

Bore φ	Rod		Add Stroke			Add 2x Stroke
	MM	φ	LV	PJ	SV	ZM
25	12		104	53	88	154
	18					
32	14		108	56	88	178
	22					
40	18		125	73	105	195
	28					
50	22		125	74	99	207
	36					
	28					
63	28		127	80	93	223
	45					
80	36		144	93	110	246
	56					
	45					
100	45		151	101	107	265
	70					
	56					
125	56		175	117	131	289
	90					
	70					
160	70		188	130	130	302
	110					
	90					
200	90		242	160	172	356
	140					
	110					

All dimensions are in millimeters unless otherwise stated.

Miller MHP Series Metric Hydraulic Cylinders

Accessory Selection

Accessories for the rod end of a cylinder are selected by reference to the rod end thread, while the same accessories, when used at the cap end, are selected by cylinder bore size. See tables of part numbers below, and on the following pages.

The rod clevises, plain rod eyes and spherical bearings fitted as accessories to the rod end have the same pin diameters as those used at the cylinder cap ends of the corresponding mounting styles – 90, 84 and 94 – when fitted with the standard rod diameter, or oversize rods with Style S rod end.

Rod and Cap End Accessories

Accessories for the MHP ISO cylinder include:

- Rod End** – rod clevis, eye bracket and pivot pin
 – plain rod eye, clevis bracket and pivot pin
 – rod eye with spherical bearing

- Cap End** – eye bracket for Model 84 mounting
 – clevis bracket for Model 90 mounting
 – pivot pin for eye bracket and clevis bracket

Rod Clevis, Eye Bracket and Pivot Pin Assembly

Thread KK	Nominal Force kN	Weight kg
M10x1.25	8	0.3
M12x1.25	12.5	0.6
M14x1.5	20	0.8
M16x1.5	32	2.2
M20x1.5	50	2.7
M27x2	80	5.9
M33x2	125	9.4
M42x2	200	17.8
M48x2	320	26.8
M64x3	500	39.0

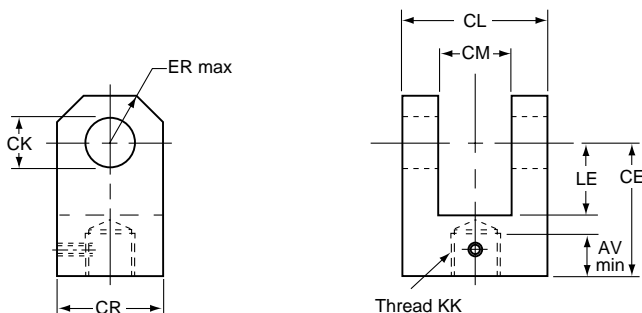

Rod Clevis

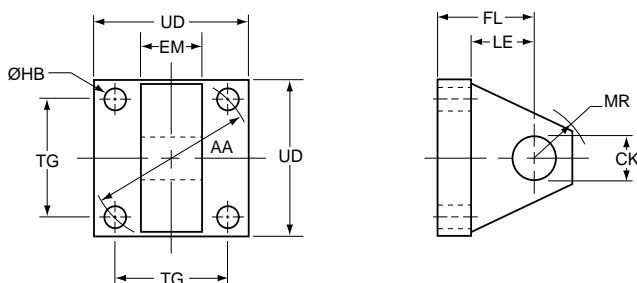

Eye Bracket

Rod Clevis Dimensions

Part No.	AV	CE	CK _{H9}	CL	CM _{A16}	CR	ER	KK	LE	Weight kg
057-RC006-M10-125	14	32	10	26	12	20	12	M10x1.25	14	0.08
057-RC006-M12-125	16	36	12	34	16	32	17	M12x1.25	19	0.25
057-RC006-M14-150	18	38	14	42	20	30	17	M14x1.5	19	0.32
057-RC006-M16-150	22	54	20	62	30	50	29	M16x1.5	32	1.0
057-RC006-M20-150	28	60	20	62	30	50	29	M20x1.5	32	1.1
057-RC006-M27-200	36	75	28	83	40	60	34	M27x2	39	2.3
057-RC006-M33-200	45	99	36	103	50	80	50	M33x2	54	2.6
057-RC006-M42-200	56	113	45	123	60	102	53	M42x2	57	5.5
057-RC006-M48-200	63	126	56	143	70	112	59	M48x2	63	7.6
057-RC006-M64-300	85	168	70	163	80	146	78	M64x3	83	13.0

Eye Bracket Dimensions

Part No.	CK _{H9}	EM _{h13}	FL	MR _{max}	LE _{min}	AA	HB	TG	UD
057-EB201-025-010	10	12	23	12	13	40	5.5	28.3	40
057-EB201-032-012	12	16	29	17	19	47	6.6	33.2	45
057-EB201-040-014	14	20	29	17	19	59	9	41.7	65
057-EB201-050-020	20	30	48	29	32	74	13.5	52.3	75
057-EB201-063-020	20	30	48	29	32	91	13.5	64.3	90
057-EB201-080-028	28	40	59	34	39	117	17.5	82.7	115
057-EB201-100-036	36	50	79	50	54	137	17.5	96.9	130
057-EB201-125-045	45	60	87	53	57	178	26	125.9	165
057-EB201-160-056	56	70	103	59	63	219	30	154.9	205
057-EB201-200-070	70	80	132	78	82	269	33	190.2	240

Pivot Pin for Clevis Bracket and Plain Rod Eye – Dimensions

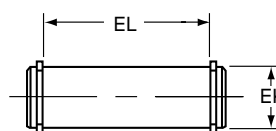

Part No.	EK _{f8}	EL	Weight kg
057-PP009-010	10	29	0.02
057-PP009-012	12	37	0.05
057-PP009-014	14	45	0.08
057-PP009-020	20	66	0.2
057-PP009-028	28	87	0.4
057-PP009-036	36	107	1.0
057-PP009-045	45	129	1.8
057-PP009-056	56	149	4.2
057-PP009-070	70	169	6.0

Eye Bracket – Cap End Mounting for Model 84

Bore ϕ	Eye Bracket	Nominal Force kN	Weight kg
25	057-EB201-025-010	8	0.2
32	057-EB201-032-012	12.5	0.3
40	057-EB201-040-014	20	0.4
50	057-EB201-050-020	32	1.0
63	057-EB201-063-020	50	1.4
80	057-EB201-080-028	80	3.2
100	057-EB201-100-036	125	5.6
125	057-EB201-125-045	200	10.5
160	057-EB201-160-056	320	15.0
200	057-EB201-200-070	500	20.0

All dimensions are in millimeters unless otherwise stated.

Miller MHP Series Metric Hydraulic Cylinders

Accessories

Plain Rod Eye, Clevis Bracket and Pivot Pin

Thread KK	Plain Rod Eye	Clevis Bracket	Pivot Pin	Nominal Force kN	Weight kg
M10x1.25	057-RE004-M10-125	057-CB001-010	057-PP009-010	8	0.5
M12x1.25	057-RE004-M12-125	057-CB001-012	057-PP009-012	12.5	1.0
M14x1.5	057-RE004-M14-150	057-CB001-014	057-PP009-014	20	1.3
M16x1.5	057-RE004-M16-150	057-CB001-020	057-PP009-020	32	3.2
M20x1.5	057-RE004-M20-150	057-CB001-020	057-PP009-020	50	3.8
M27x2	057-RE004-M27-200	057-CB001-028	057-PP009-028	80	6.9
M33x2	057-RE004-M33-200	057-CB001-036	057-PP009-036	125	12.5
M42x2	057-RE004-M42-200	057-CB001-045	057-PP009-045	200	26.0
M48x2	057-RE004-M48-200	057-CB001-056	057-PP009-056	320	47.0
M64x3	057-RE004-M64-300	057-CB001-070	057-PP009-070	500	64.0

Plain Rod Eye Dimensions

Part No.	AW	CA	CB	CD	CK H9	EM h13	ER	KK	LE	Weight kg
057-RE004-M10-125	14	32	18	9	10	12	12	M10x1.25	13	0.08
057-RE004-M12-125	16	36	22	11	12	16	17	M12x1.25	19	0.15
057-RE004-M14-150	18	38	20	12.5	14	20	17	M14x1.5	19	0.22
057-RE004-M16-150	22	54	30	17.5	20	30	29	M16x1.5	32	0.5
057-RE004-M20-150	28	60	30	20	20	30	29	M20x1.5	32	1.1
057-RE004-M27-200	36	75	40	25	28	40	34	M27x2	39	1.5
057-RE004-M33-200	45	99	50	35	36	50	50	M33x2	54	2.5
057-RE004-M42-200	56	113	65	50	45	60	53	M42x2	57	4.2
057-RE004-M48-200	63	126	90	56	56	70	59	M48x2	63	11.8
057-RE004-M64-300	85	168	110	70	70	80	78	M64x3	83	17.0

Plain Rod Eye

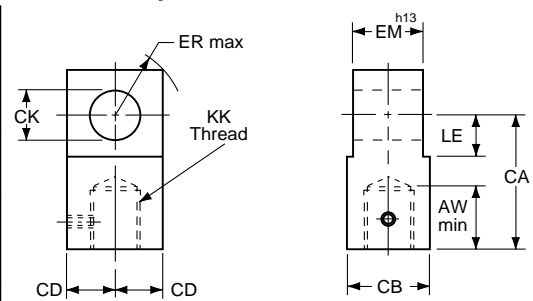

Clevis Bracket

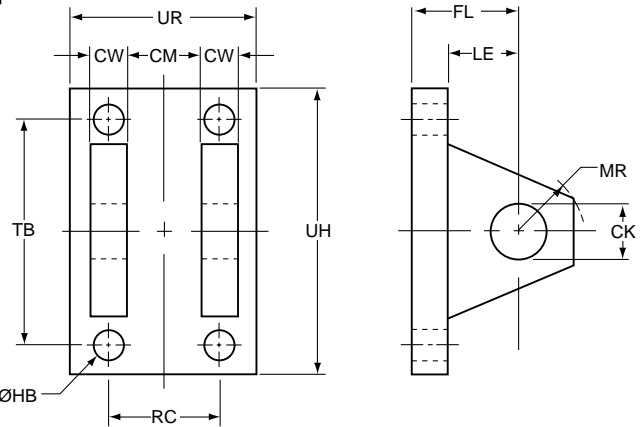

Clevis Bracket Dimensions

Part No.	CK H9	CM A16	CW	FL	MR max	HB	LE min	RC	TB	UR	UH
057-CB001-010	10	12	6	23	12	5.5	13	18	47	35	60
057-CB001-012	12	16	8	29	17	6.6	19	24	57	45	70
057-CB001-014	14	20	10	29	17	9	19	30	68	55	85
057-CB001-020	20	30	15	48	29	13.5	32	45	102	80	125
057-CB001-028	28	40	20	59	34	17.5	39	60	135	100	170
057-CB001-036	36	50	25	79	50	17.5	54	75	167	130	200
057-CB001-045	45	60	30	87	53	26	57	90	183	150	230
057-CB001-056	56	70	35	103	59	30	63	105	242	180	300
057-CB001-070	70	80	40	132	78	33	82	120	300	200	360

Clevis Bracket – For Model 90

Bore ϕ	Clevis Bracket	Nominal Force kN	Weight kg
25	057-CB001-010	8	0.4
32	057-CB001-012	12.5	0.8
40	057-CB001-014	20	1.0
50	057-CB001-020	32	2.5
63	057-CB001-020	50	2.5
80	057-CB001-028	80	5.0
100	057-CB001-036	125	9.0
125	057-CB001-045	200	20.0
160	057-CB001-056	320	31.0
200	057-CB001-070	500	41.0

Pivot Pin for Clevis Bracket and Plain Rod Eye – Dimensions

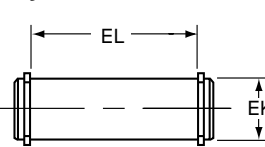

Part No.	EK f8	EL	Weight kg
057-PP009-010	10	29	0.02
057-PP009-012	12	37	0.05
057-PP009-014	14	45	0.08
057-PP009-020	20	66	0.2
057-PP009-028	28	87	0.4
057-PP009-036	36	107	1.0
057-PP009-045	45	129	1.8
057-PP009-056	56	149	4.2
057-PP009-070	70	169	6.0

All dimensions are in millimeters unless otherwise stated.

Miller MHP Series Metric Hydraulic Cylinders

Rod Eye with Spherical Bearing, Mounting Bracket and Pivot Pin

Thread KK	Rod Eye with Spherical Bearing	Mounting Bracket and Pivot Pin	Nominal Force kN	Weight kg
M10x1.25	057-SRE03-M10-125	057-SCB01-012	8	0.2
M12x1.25	057-SRE03-M12-125	057-SCB01-016	12.5	0.3
M14x1.5	057-SRE03-M14-150	057-SCB01-020	20	0.4
M16x1.5	057-SRE03-M16-150	057-SCB01-025	32	0.7
M20x1.5	057-SRE03-M20-150	057-SCB01-030	50	1.3
M27x2	057-SRE03-M27-200	057-SCB01-040	80	2.3
M33x2	057-SRE03-M33-200	057-SCB01-050	125	4.4
M42x2	057-SRE03-M42-200	057-SCB01-060	200	8.4
M48x2	057-SRE03-M48-200	057-SCB01-080	320	15.6
M64x3	057-SRE03-M64-300	057-SCB01-100	500	28.0

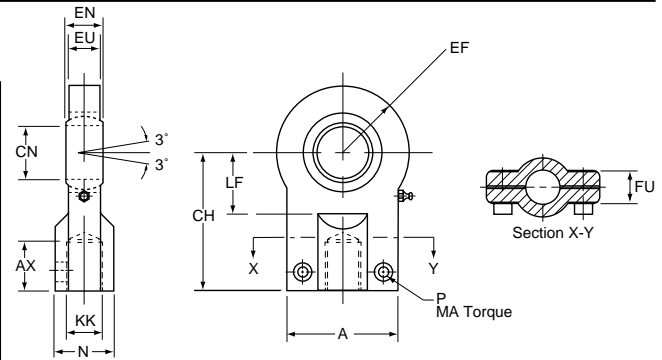

Rod Eye with Spherical Bearing

All spherical bearings should be re-packed with grease when servicing. In unusual or severe working conditions, consult the factory regarding the suitability of the bearing chosen.

Rod Eye with Spherical Bearing Dimensions

Part No.	A max	AX min	EF max	CH	CN	EN	EU	FU	KK	LF min	N max	MA max Nm	P
057-SRE03-M10-125	40	15	20	42	12 -0.008	10 -0.012	8	13	M10x1.25	16	17	10	M6
057-SRE03-M12-125	45	17	22.5	48	16 -0.008	14 -0.012	11	13	M12x1.25	20	21	10	M6
057-SRE03-M14-150	55	19	27.5	58	20 -0.012	16 -0.012	13	17	M14x1.5	25	25	25	M8
057-SRE03-M16-150	62	23	32.5	68	25 -0.012	20 -0.012	17	17	M16x1.5	30	30	25	M8
057-SRE03-M20-150	80	29	40	85	30 -0.012	22 -0.012	19	19	M20x1.5	35	36	45	M10
057-SRE03-M27-200	90	37	50	105	40 -0.012	28 -0.012	23	23	M27x2	45	45	45	M10
057-SRE03-M33-200	105	46	62.5	130	50 -0.012	35 -0.012	30	30	M33x2	58	55	80	M12
057-SRE03-M42-200	134	57	80	150	60 -0.015	44 -0.015	38	38	M42x2	68	68	160	M16
057-SRE03-M48-200	156	64	102.5	185	80 -0.015	55 -0.015	47	47	M48x2	92	90	310	M20
057-SRE03-M64-300	190	86	120	240	100 -0.020	70 -0.020	57	57	M64x3	116	110	530	M24

Mounting Bracket and Pivot Pin Dimensions - For Model 94

Part No.	CF K7/h6	CG +0.1,+0.3	CO N9	CP	FM js11	FO js14	GL js13	HB	KC 0,+0.30	LG	LJ	LO	RE js13	SR max	TA js13	UJ	UK
057-SCB01-012	12	10	10	30	40	16	46	9	3.3	28	29	56	55	12	40	75	60
057-SCB01-016	16	14	16	40	50	18	61	11	4.3	37	38	74	70	16	55	95	80
057-SCB01-020	20	16	16	50	55	20	64	14	4.3	39	40	80	85	20	58	120	90
057-SCB01-025	25	20	25	60	65	22	78	16	5.4	48	49	98	100	25	70	140	110
057-SCB01-030	30	22	25	70	85	24	97	18	5.4	62	63	120	115	30	90	160	135
057-SCB01-040	40	28	36	80	100	24	123	22	8.4	72	73	148	135	40	120	190	170
057-SCB01-050	50	35	36	100	125	35	155	30	8.4	90	92	190	170	50	145	240	215
057-SCB01-060	60	44	50	120	150	35	187	39	11.4	108	110	225	200	60	185	270	260
057-SCB01-080	80	55	50	160	190	35	255	45	11.4	140	142	295	240	80	260	320	340
057-SCB01-100	100	70	63	200	210	35	285	48	12.4	150	152	335	300	100	300	400	400

Cap Mounting Bracket and Pivot Pin

Bore φ	Mounting Bracket and Pivot Pin	Nominal Force kN	Weight kg
25	057-SCB01-012	8	0.6
32	057-SCB01-016	12.5	1.3
40	057-SCB01-020	20	2.1
50	057-SCB01-025	32	3.2
63	057-SCB01-030	50	6.5
80	057-SCB01-040	80	12.0
100	057-SCB01-050	125	23.0
125	057-SCB01-060	200	37.0
160	057-SCB01-080	320	79.0
200	057-SCB01-100	500	140.0

Mounting Bracket and Pivot Pin

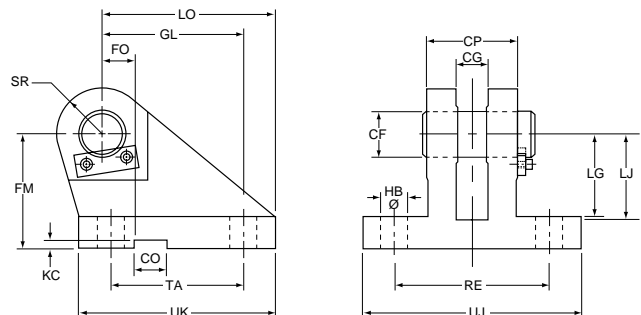

All dimensions are in millimeters unless otherwise stated.

Miller MHP Series Metric Hydraulic Cylinders

Mounting Styles

General guidance for the selection of ISO mounting styles is given on Mounting Styles page. The notes which follow provide information for use in specific applications and should be read in conjunction with the information on Mounting Styles page.

Trunnions

Trunnions require lubricated pillow blocks with minimum bearing clearances. Blocks should be aligned and mounted to eliminate bending moments on the trunnion pins. Self-aligning mounts must not be used to support the trunnions as bending forces can develop.

Intermediate trunnions may be positioned at any point on the cylinder body. This position, dimension XI, should be specified at the time of order. Trunnions are not field adjustable.

Flange Mountings

Front flange-mounted (Model 67) cylinders incorporate a pilot diameter for accurate alignment on the mounting surface – see rod end dimensions for MHP cylinders. The bushing retainer is integral with the head on 25, 32 and 40mm bore cylinders, while on 50mm bores and above, the circular retainer is bolted to the head.

Extended Tie Rods

Cylinders may be ordered with extended tie rods in addition to another mounting style. The extended tie rods may then be used for mounting other systems or machine components.

Pivot Mountings

Pivot pins are supplied with Model 84 cap fixed clevis mounted cylinders. Pivot pins are not supplied with the cap fixed eye mounting, Model 90, or the cap with spherical bearing, Model 94, where pin length will be determined by the customer's equipment.

Spherical Bearings

The service life of a spherical bearing is influenced by such factors as bearing pressure, load direction, sliding velocity and frequency of lubrication. When considering severe or unusual working conditions, please consult the factory.

Foot Mountings and Thrust Keys

The bending moment which results from the application of force by a foot mounted cylinder must be resisted by secure mounting and effective guidance of the load. A thrust key modification is recommended to provide positive cylinder location.

Thrust key mountings eliminate the need for fitted bolts or external keys on Model 72 side mounted cylinders. The bushing retainer plate is extended below the nominal mounting surface to fit into a keyway milled into the mounting surface of the machine member.

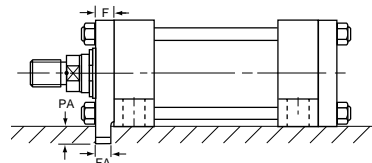

Bore φ	F	FA	PA
	Nominal	-0.075	-0.2
25	10	8	5
32	10	8	5
40	10	8	5
50	16	14	8
63	16	14	8
80	20	18	10
100	22	22	11
125	22	22	11
160	25	25	13
200	25	25	13

Mounting Bolts and Nuts

Miller Fluid Power recommends that mounting bolts with a minimum strength of ISO 898/1 grade 10.9 should be used for fixing cylinders to the machine or base. This recommendation is of particular importance where bolts are placed in tension or subjected to shear forces. Mounting bolts, with lubricated threads, should be torque loaded to their manufacturer's recommended figures. Tie rod mounting nuts should be to a minimum strength of ISO 898/2 grade 10, torque loaded to the figures shown.

Bore φ	Tie Rod Torque Nm
25	4.5-5.0
32	7.6-9.0
40	19.0-20.5
50	68-71
63	68-71
80	160-165
100	160-165
125	450-455
160	815-830
200	1140-1155

WARNING

Piston rods are not normally designed to absorb bending moments or loads which are perpendicular to the axis of piston rod motion. These additional loads can cause the piston rod to fail. If these types of additional loads are expected to be imposed on the piston rod, their magnitude should be made known to our engineering department.

The cylinder user should always make sure that the piston rod is securely attached to the machine member.

On occasion cylinders are ordered with double piston rods. In some cases a stop is threaded onto one of the piston rods and used as an external stroke adjuster. The external stop will create a pinch point and the user should consider appropriate use of guards. If the external stop is not perpendicular to the contact surface it will place a bending moment on the piston rod which can lead to piston rod failure. An external stop will also negate the effect of a cushion and will subject the piston rod to impact loading. These two (2) conditions can cause piston rod failure. The use of an external stroke adjuster should be reviewed with our engineering department.

All dimensions are in millimeters unless otherwise stated.

Miller MHP Series Metric Hydraulic Cylinders

Intermediate or Additional Mountings

Long cylinders with fixed mountings such as extended tie rods may require additional support to counter sagging or the effects of vibration. This may be provided mid-way along the cylinder body in the form of an intermediate mounting or, with end-mounted cylinders, as an additional mounting supporting the free end of the cylinder. Please contact the factory for further information. The maximum unsupported stroke lengths which Miller Fluid Power recommends for each bore size are shown in the table below.

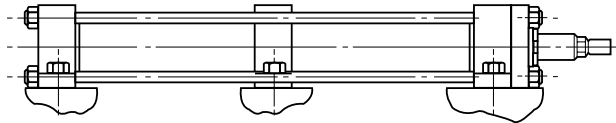

Intermediate Foot Mounting

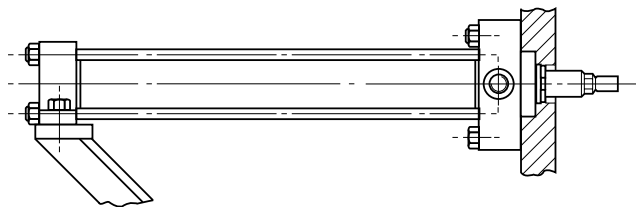

End Support Mounting

Maximum Stroke Lengths of Unsupported Cylinders (in mm)

Bore ϕ	Intermediate Mounting	End Support Mounting
25	1500	1000
32		
40		
50	2000	1500
63		
80		
100	3000	2000
125		
160		
200	3500	2500

All dimensions are in millimeters unless otherwise stated.

Tie Rod Supports

To increase the resistance to buckling of long stroke cylinders, tie rod supports may be fitted. These move the tie rods radially outwards and allow longer than normal strokes to be used without the need for an additional mounting.

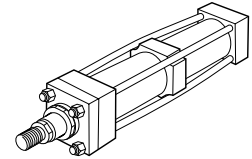

Bore ϕ	Stroke (meters)												No. of Supports Req'd.	
	0.9	1.2	1.5	1.8	2.1	2.4	2.7	3.0	3.3	3.6	3.9	4.2		
25	1	1	2											Consult Factory
32	-	1	1	2										
40	-	-	1	1	1	2	2							
50	-	-	-	1	1	1	1	2	2	2	2	3		
63	-	-	-	-	-	1	1	1	1	1	2	2		
80	-	-	-	-	-	-	-	1	1	1	1	1		
100	-	-	-	-	-	-	-	-	-	1	1	1		

Stroke Tolerances

Stroke length tolerances are required due to the build-up of tolerances of piston, head, cap and cylinder body. Standard production stroke tolerances are 0 to +2mm on all bore sizes and stroke lengths. For closer tolerances, please specify the required tolerance plus the operating temperature and pressure. Stroke tolerances of less than 0.4mm are generally impracticable due to the elasticity of cylinders. In these cases, the use of a stroke adjuster should be considered. Tolerances of stroke dependent dimensions for each mounting style are shown in the table below.

Stroke Dependent Tolerances

Mounting Style	Dimensions	Tolerance - for strokes up to 3m
All styles - port dimensions	Y	± 2
	PJ	± 1.25
	ZB	max
67 (ME5)	ZB	max
68 (ME6)	ZJ	± 1
84 (MP1) 90 (MP3)	XC	± 1.25
94 (MP5)	XO	± 1.25
72 (MS2)	XS	± 2
	ZB	max
	SS	± 1.25
81 (MT1)	XG	± 2
	ZB	max
82 (MT2)	XJ	± 1.25
	ZB	max
89 (MT4)	XV	± 2
	ZB	max
51 (MX1) 52 (MX2) 53 (MX3)	BB	+3 0
	ZB	max
	WH	± 2
51 (MX1) 52 (MX2) 53 (MX3)	ZJ	± 1

Miller MHP Series Metric Hydraulic Cylinders

Theoretical Push and Pull Forces
Stroke Factors

Calculation of Cylinder Diameter

General Formula

The cylinder output forces are derived from the formula:

$$F = \frac{P \times A}{10000}$$

Where F = Force in kN.

P = Pressure at the cylinder in bar.

A = Effective area of cylinder piston in square mm.

Prior to selecting the cylinder bore size, properly size the piston rod for tension (pull) or compression (push) loading (see the Piston Rod Selection Chart).

If the piston rod is in compression, use the 'Push Force' table below, as follows:

1. Identify the operating pressure closest to that required.
2. In the same column, identify the force required to move the load (always rounding up).
3. In the same row, look along to the cylinder bore required.

Push Force

Bore ϕ	Bore Area	Cylinder Push Force in kN						
		10 bar	40 bar	63 bar	100 bar	125 bar	160 bar	210 bar
mm	sq. mm							
25	491	0.5	2.0	3.1	4.9	6.1	7.9	10.3
32	804	0.8	3.2	5.1	8.0	10.1	12.9	16.9
40	1257	1.3	5.0	7.9	12.6	15.7	20.1	26.4
50	1964	2.0	7.9	12.4	19.6	24.6	31.4	41.2
63	3118	3.1	12.5	19.6	31.2	39.0	49.9	65.5
80	5027	5.0	20.1	31.7	50.3	62.8	80.4	105.6
100	7855	7.9	31.4	49.5	78.6	98.2	125.7	165.0
125	12272	12.3	49.1	77.3	122.7	153.4	196.4	257.7
160	20106	20.1	80.4	126.7	201.1	251.3	321.7	422.2
200	31416	31.4	125.7	197.9	314.2	392.7	502.7	659.7

Stroke Factors

The stroke factors below are used in the calculation of cylinder 'basic length' – see Piston Rod Size Selection.

Rod End Connection	Mounting Style	Type of Mounting	Stroke Factor
Fixed and Rigidly Guided	53, 51, 72, 67		0.5
Pivoted and Rigidly Guided	53, 51, 72, 67		0.7
Fixed and Rigidly Guided	52, 68		1.0
Pivoted and Rigidly Guided	81		1.0

If the cylinder envelope dimensions are too large for the application, increase the operating pressure, if possible, and repeat the exercise.

If the piston rod is in tension, use the 'Deduction for Pull Force' table. The procedure is the same but, due to the reduced area caused by the piston rod, the force available on the 'pull' stroke will be smaller. To determine the pull force:

1. Follow the procedure for 'push' applications as described above.
2. Using the 'pull' table, identify the force indicated according to the rod and pressure selected.
3. Deduct this from the original 'push' force. The resultant is the net force available to move the load.

If this force is not large enough, repeat the process and increase the system operating pressure or cylinder diameter if possible. For assistance, contact your local authorized Miller Fluid Power distributor.

Deduction for Pull Force

Piston Rod ϕ	Piston Rod Area	Reduction in Force in kN						
		10 bar	40 bar	63 bar	100 bar	125 bar	160 bar	210 bar
mm	sq. mm							
12	113	0.1	0.5	0.7	1.1	1.4	1.8	2.4
14	154	0.2	0.6	1.0	1.5	1.9	2.5	3.2
18	255	0.3	1.0	1.6	2.6	3.2	4.1	5.4
22	380	0.4	1.5	2.4	3.8	4.8	6.1	8.0
28	616	0.6	2.5	3.9	6.2	7.7	9.9	12.9
36	1018	1.0	4.1	6.4	10.2	12.7	16.3	21.4
45	1591	1.6	6.4	10.0	15.9	19.9	25.5	33.4
56	2463	2.5	9.9	15.6	24.6	30.8	39.4	51.7
70	3849	3.8	15.4	24.2	38.5	48.1	61.6	80.8
90	6363	6.4	25.5	40.1	63.6	79.6	101.8	133.6
110	9505	9.5	38.0	59.9	95.1	118.8	152.1	199.6
140	15396	15.4	61.6	97.0	154.0	192.5	246.3	323.3

Rod End Connection	Mounting Style	Type of Mounting	Stroke Factor
Pivoted and Rigidly Guided	52, 68, 89		1.5
Supported but not Rigidly Guided	53, 51, 72, 67		2.0
Pivoted and Rigidly Guided	90, 84, 82, 94		2.0
Pivoted and Supported but Rigidly Guided	89		3.0

Miller MHP Series Metric Hydraulic Cylinders

Piston Rod Size Selection

To select a piston rod for thrust (push) applications, follow these steps:

1. Determine the type of cylinder mounting style and rod end connection to be used. Consult the Stroke Factor table and determine which factor corresponds to the application.
2. Using the appropriate stroke factor, determine the 'basic length' from the equation:
$$\text{Basic Length} = \text{Net Stroke} \times \text{Stroke Factor}$$

(The graph is prepared for standard rod extensions beyond the face of the bushing retainers. For rod extensions greater than standard, add the increases to the net stroke to arrive at the 'basic length'.)
3. Calculate the load imposed for the thrust application by multiplying the full bore area of the cylinder by the system pressure, or by referring to the Push and Pull Force charts.
4. Using the graph below, look along the values of 'basic length' and 'thrust' as found in 2 and 3 above, and note the point of intersection.

The correct piston rod size is read from the diagonally curved line labelled 'Rod Diameter' above the point of intersection.

Stop Tubes

The required length of stop tube, where necessary, is read from the vertical columns on the right of the graph below by following the horizontal band within which the point of intersection, determined in steps 2 and 3 above, lies.

Note that stop tube requirements differ for fixed and pivot mounted cylinders.

If the required length of stop tube is in the region labeled 'consult factory', please submit the following information:

1. Cylinder mounting style.
2. Rod end connection and method of guiding load.
3. Bore required, stroke, length of rod extension (dimensions WF) if greater than standard.
4. Mounting position of cylinder. (Note: if at an angle or vertical, specify the direction of the piston rod.)
5. Operating pressure of cylinder, if limited to less than the standard pressure for the cylinder selected.

When specifying a cylinder with a stop tube, state the **gross** stroke of the cylinder and the length of the stop tube. The gross stroke is equal to the net (working) stroke of the cylinder plus the stop tube length.

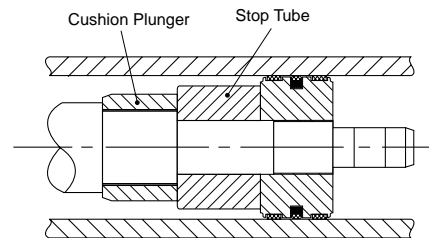

Long Stroke Cylinders

When considering the use of long stroke cylinders, the piston rod should be of sufficient diameter to provide the necessary column strength.

For tensile (pull) loads, the rod size is selected by specifying standard cylinders with standard rod diameters and using them at or below the rated pressure.

For long stroke cylinders under compressive loads, the use of stop tubes should be considered, to reduce bearing stress. The Piston Rod Selection Chart in this catalog provides guidance where unusually long strokes are required.

Piston Rod Selection Chart

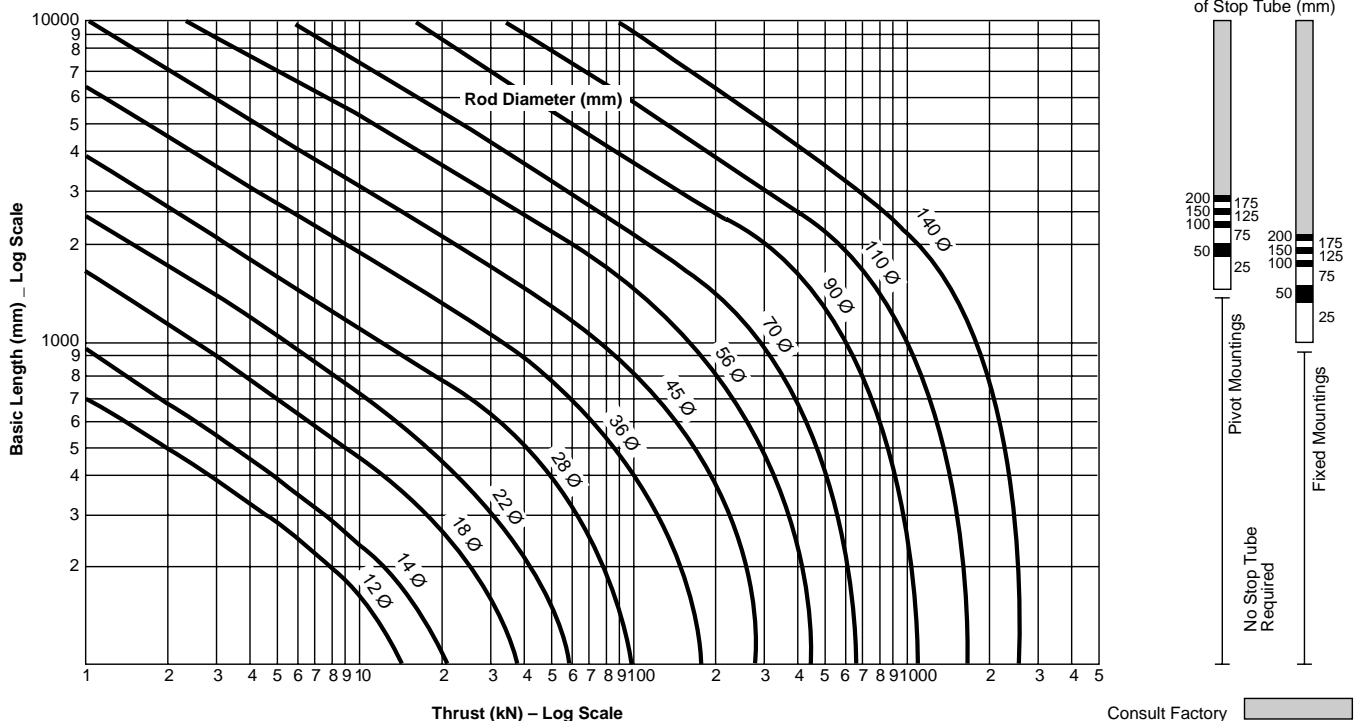

Miller MHP Series Metric Hydraulic Cylinders

An Introduction to Cushioning

Cushioning is recommended as a means of controlling the deceleration of masses, or for applications where piston speeds are in excess of 0.1m/s and the piston will make a full stroke. Cushioning extends cylinder life and reduces undesirable noise and hydraulic shock.

Built-in 'cushions' are optional and can be supplied at the head and cap ends of the cylinder without affecting its envelope or mounting dimensions.

Standard Cushioning

Ideal cushion performance shows an almost uniform absorption of energy along the cushioning length, as shown.

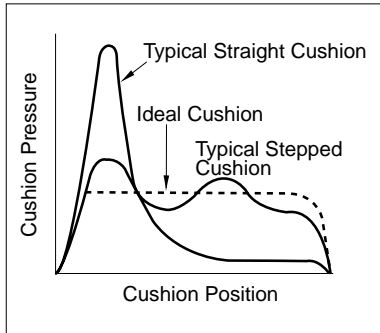

Many forms of cushioning exist, and each has its own specific merits and advantages. In order to cover the majority of applications, MHP cylinders are supplied with profiled cushioning as standard. Final speed may be adjusted using the cushion screws.

The performance of profiled cushioning is indicated on the diagram, and cushion performance for each of the rod sizes available is illustrated graphically in the charts on the next page.

Note: Cushion performance will be affected by the use of water or high water based fluids. Please consult the factory for details.

Cushion Length

Where specified, MHP cylinders incorporate the longest cushion plungers that can be accommodated within the standard envelope without reducing the rod bearing and piston bearing lengths. See Cushion Length Table for specific dimensions. Cushions are adjustable via recessed needle valves.

Cushion Calculations

The charts on the next page show the energy absorption capacity for each bore/rod combination at the head (annulus) and the cap (full bore) ends of the cylinder. The charts are valid for piston velocities in the range 0.1 to 0.3m/s. For velocities between 0.3 and 0.5m/s, the energy values derived from the charts should be reduced by 25%. For velocities of less than 0.1m/s where large masses are involved, and for velocities of greater than 0.5m/s, a special cushion profile may be required. Please consult the factory for details.

The cushion capacity of the head end is less than that of the cap, and reduces to zero at high drive pressures due to the pressure intensification effect across the piston.

The energy absorption capacity of the cushion decreases with drive pressure.

Formula

Cushioning calculations are based on the formula $E = \frac{1}{2}mv^2$ for horizontal applications. For inclined or vertically downward or upward applications, this is modified to:

$$E = \frac{1}{2}mv^2 + mgl \times 10^{-3} \times \sin\alpha$$

(for inclined or vertically downward direction of mass)

$$E = \frac{1}{2}mv^2 - mgl \times 10^{-3} \times \sin\alpha$$

(for inclined or vertically upward direction of mass)

Where:

E = energy absorbed in Joules

g = acceleration due to gravity = 9.81m/s²

v = velocity in meters/second

l = length of cushion in millimeters

m = mass of load in kilograms (including piston, rod and rod end accessories)

α = angle to the horizontal in degrees

p = pressure in bar

Example

The following example shows how to calculate the energy developed by masses moving in a straight line. For non-linear motion, other calculations are required; please consult the factory. The example assumes that the bore and rod diameters are already appropriate for the application. The effects of friction on the cylinder and load have been ignored.

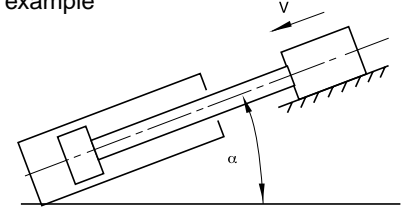

Selected bore/rod 160/70mm (No.1 rod).
Cushioning at the cap end.

Pressure =	160 bar
Mass =	10000kg
Velocity =	0.4m/s
Cushion length =	41mm
α =	45°
$\sin\alpha$ =	0.70

$$E = \frac{1}{2}mv^2 + mgl \times 10^{-3} \times \sin\alpha$$

$$= \frac{10000 \times 0.4^2}{2} + 10000 \times 9.81 \times \frac{41}{10^3} \times 0.70$$

$$= 800 + 2815 = 3615 \text{ Joules}$$

Note that velocity is greater than 0.3m/s; therefore, a de-rating factor of 0.75 must be applied before comparison with the curves on the cushioning charts. Applying this factor to the calculated energy figure of 3615 Joules gives a corrected energy figure of:

$$\frac{3615}{0.75} = 4820 \text{ Joules}$$

Comparison with the curve shows that the standard cushion can safely decelerate this load. If the calculated energy exceeds that indicated by the curve, select a larger bore cylinder and re-calculate.

Miller MHP Series Metric Hydraulic Cylinders

Cushioning

Cushion Energy Absorption Capacity Data

The cushion energy absorption capacity data shown below is based on the maximum fatigue-free pressure developed in the tube. For applications with a life cycle of less than

10^6 cycles, greater energy absorption figures can be applied. Please consult the factory if further information is required.

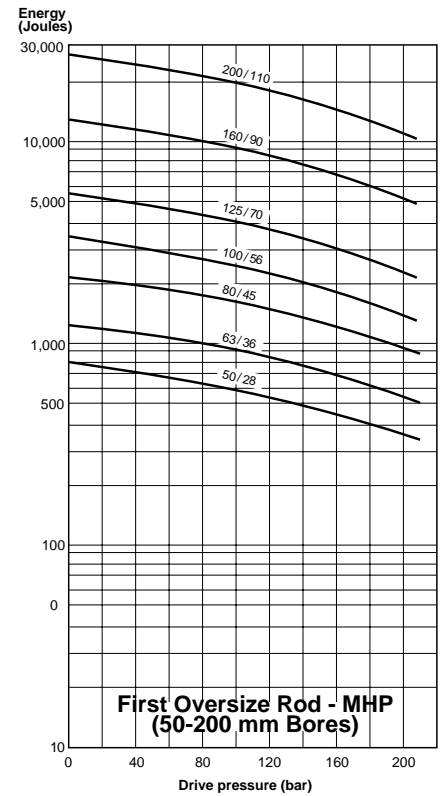
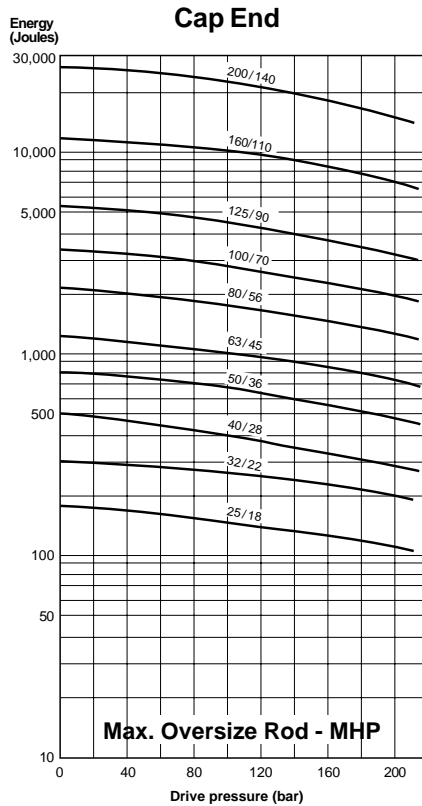
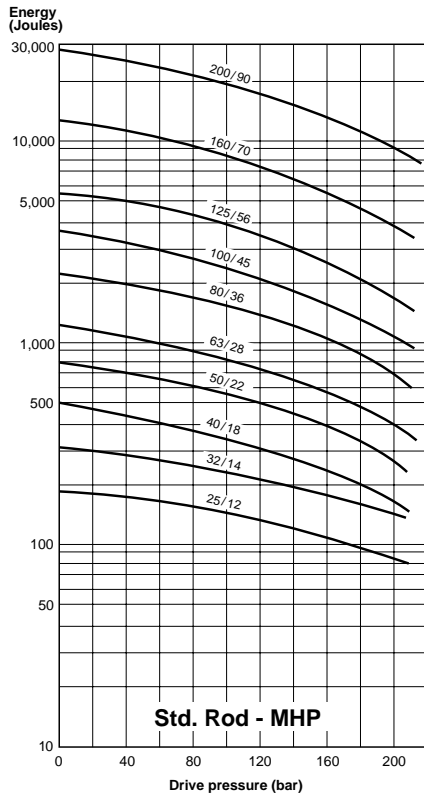
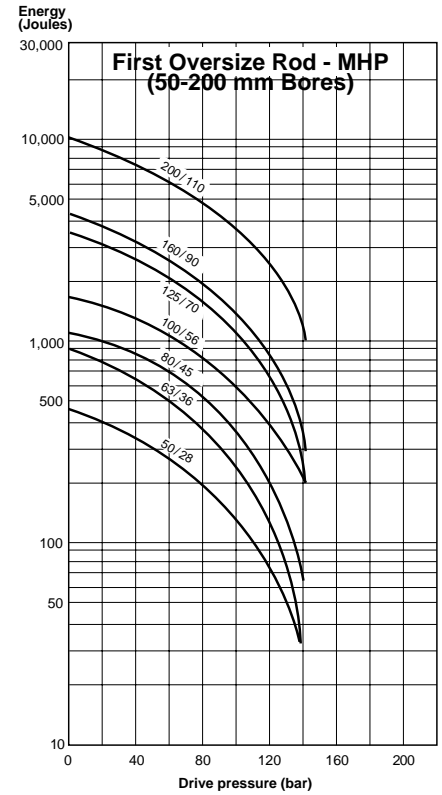
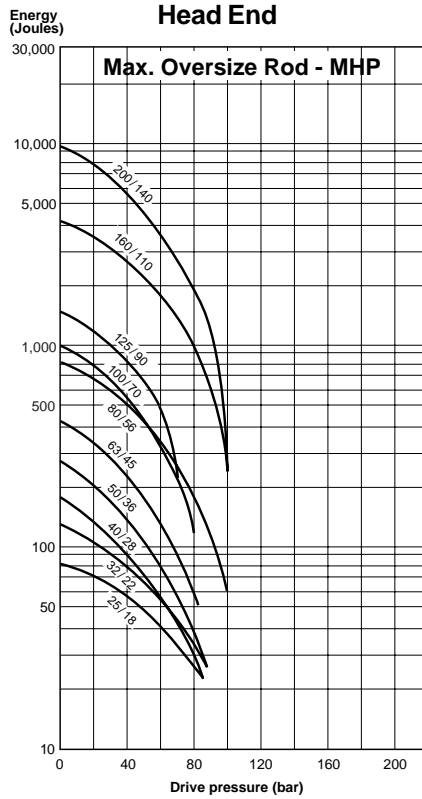
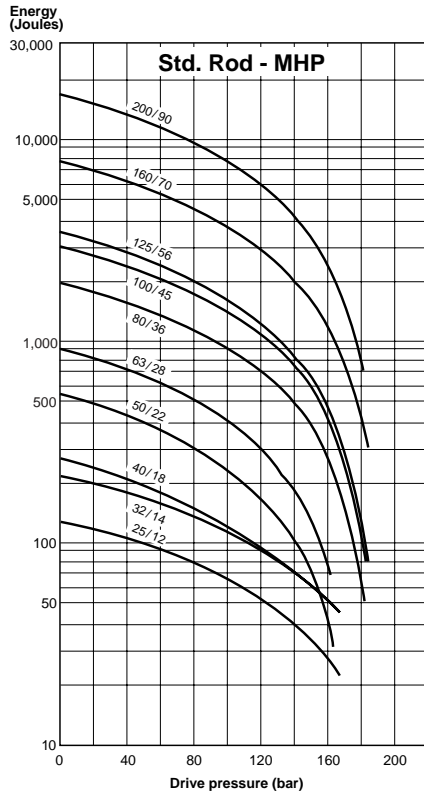

Miller MHP Series Metric Hydraulic Cylinders

Cushioning,
Pressure Limitations

Cushion Length, Piston and Rod Mass

Bore ϕ	Rod ϕ	Cushion Length						Mass	
		Standard Rod		Max. Oversize Rod		First Oversize Rod		Piston & Rod Zero Stroke kg	Rod Only per 10mm Stroke kg
		Head	Cap	Head	Cap	Head	Cap		
25	12	22	20	24	20	-	-	0.12	0.01
	18							0.16	0.02
32	14	24	20	24	20	-	-	0.23	0.01
	22							0.30	0.03
40	18	29	29	29	30	-	-	0.44	0.02
	28							0.60	0.05
50	22	29	29	29	29	29	29	0.70	0.03
	36							0.80	0.05
	28							0.95	0.08
63	28	29	29	29	29	29	29	1.20	0.05
	45							1.35	0.08
	36							1.60	0.12
80	36	35	32	27	32	35	32	2.30	0.08
	56							2.50	0.12
	45							2.90	0.19
100	45	35	32	26	32	29	32	4.00	0.12
	70							4.40	0.19
	56							5.10	0.30
125	56	28	32	27	32	27	32	7.10	0.19
	90							8.00	0.30
	70							9.40	0.50
160	70	34	41	34	41	34	41	13.70	0.30
	110							15.30	0.50
	90							17.20	0.75
200	90	46	56	49	56	50	56	27.00	0.50
	140							30.00	0.75
	110							34.00	1.23

Pressure Limitations – Introduction

The pressure limitations of a hydraulic cylinder must be reviewed when considering its application. To assist the designer in obtaining the optimum performance from a cylinder, the information which follows highlights the recommended minimum and maximum pressures according to application. If in doubt, please consult the factory.

Minimum Pressure

Due to factors such as seal friction, the minimum operating pressure for MHP cylinders is 5 bar. Below this pressure, low friction seals should be specified. If in doubt, please consult the factory.

Maximum Pressure

MHP cylinders are designed to the mounting dimensions specified in ISO 6020/2 for 160 bar cylinders but, due to the selection of materials, they can be used at higher pressures depending on the application and the choice of rod size and rod end style. As a result, the majority of these cylinders can be operated at 210 bar.

All dimensions are in millimeters unless otherwise stated.

Cylinder Tube (Pressure Envelope)

In many applications, the pressure developed within a cylinder may be greater than the working pressure, due to pressure intensification across the piston and during cushioning. In most cases, this intensification does not affect the cylinder mountings or piston rod threads in the form of increased loading. It may, however, affect the cylinder tube and induce fatigue failure or cause premature seal wear. It is important, therefore, that the pressure due to cushioning or intensification does not exceed the 340 bar fatigue limit of the cylinder tube. The cushion energy absorption data on the previous page is based on this maximum induced pressure. If in doubt, please consult the factory.

Miller MHP Series Metric Hydraulic Cylinders

Storage and Installation
Mounting Recommendations
Cylinder Troubleshooting

Storage

At times cylinders are delivered before a customer is ready to install them and must be stored for a period of time. When storage is required the following procedures are recommended.

1. Store the cylinders in an indoor area which has a dry, clean and noncorrosive atmosphere. Take care to protect the cylinder from both internal corrosion and external damage.
2. Whenever possible cylinders should be stored in a vertical position (piston rod up). This will minimize corrosion due to possible condensation which could occur inside the cylinder. This will also minimize seal damage.
3. Port protector plugs should be left in the cylinder until the time of installation.
4. If a cylinder is stored full of hydraulic fluid, expansion of the fluid due to temperature changes must be considered. Installing a check valve with free flow out of the cylinder is one method.

Installation

1. Cleanliness is an important consideration, and Miller cylinders are shipped with the ports plugged to protect them from contaminants entering the ports. These plugs should not be removed until the piping is to be installed. Before making the connection to the cylinder ports, piping should be thoroughly cleaned to remove all chips or burrs which might have resulted from threading or flaring operations.
2. Cylinders operating in an environment where air drying materials are present such as fast-drying chemicals, paint, or weld splatter, or other hazardous conditions such as excessive heat, should have shields installed to prevent damage to the piston rod and piston rod seals.
3. Proper alignment of the cylinder piston rod and its mating component on the machine should be checked in both the extended and retracted positions. Improper alignment will result in excessive rod bushing and/or cylinder bore wear. On fixed mounting cylinders attaching the piston rod while the rod is retracted will help in achieving proper alignment.

Mounting Recommendations

1. Always mount cylinders using the largest possible high tensile alloy steel socket head screws that can fit in the cylinder mounting holes and torque them to the manufacturer's recommendations for their size.
2. Side-Mounted Cylinders – In addition to the mounting bolts, cylinders of this type should be equipped with thrust keys or dowel pins located so as to resist the major load.
3. Tie Rod Mounting – Cylinders with tie rod mountings are recommended for applications where mounting space is limited. The standard tie rod extension is shown as BB in dimension tables. Longer or shorter extensions can be supplied. Nuts used for this mounting style should be torqued to the same value as the tie rods for that bore size.
4. Flange Mount Cylinders – The controlled diameter of the rod bushing extension on head end flange mount cylinders can be used as a pilot to locate the cylinders in relation to the machine. After alignment has been obtained, the flanges may be drilled for pins or dowels to prevent shifting.
5. Trunnion Mountings – Cylinders require lubricated bearing blocks with minimum bearing clearances. Bearing blocks should be carefully aligned and rigidly mounted so the trunnions will not be subjected to bending moments. The rod end should also be pivoted with the pivot pin in line and parallel to axis of the trunnion pins.
6. Clevis Mountings – Cylinders should be pivoted at both ends with centerline of pins parallel to each other. After cylinder is mounted, be sure to check to assure that the cylinder is free to swing through its working arc without interference from other machine parts.

Cylinder Trouble Shooting

External Leakage

1. Rod seal leakage can generally be traced to worn or damaged seals. Examine the piston rod for dents, gouges or score marks, and replace piston rod if surface is rough.

Rod seal leakage could also be traced to bushing wear. If clearance is excessive, replace rod bushing and seal. Rod seal leakage can also be traced to seal deterioration. If seals are soft or gummy or brittle, check compatibility of seal material with lubricant used if air cylinder, or operating fluid if hydraulic cylinder. Replace with seal material, which is compatible with these fluids. If the seals are hard or have lost elasticity, it is usually due to exposure to temperatures in excess of 165°F. (+74°C). Shield the cylinder from the heat source to limit temperature to 350°F. (+177°C.) and replace with fluorocarbon seals.

2. Cylinder tube seal leak can generally be traced to loose tie rods. Torque the tie rods to manufacturer's recommendation for that bore size.

Excessive pressure can also result in cylinder tube seal leak. Determine maximum pressure to rated limits. Replace seals and retorque tie rods as in paragraph above. Excessive pressure can also result in cylinder tube seal leak. Determine if the pressure rating of the cylinder has been exceeded. If so, bring the operating pressure down to the rating of the cylinder and have the tie rods replaced.

Pinched or extruded cylinder tube seal will also result in a leak. Replace cylinder tube seal and retorque as in paragraph above.

Cylinder tube seal leakage due to loss of radial squeeze which shows up in the form of flat spots or due to wear on the O.D. or I.D. – Either of these are symptoms of normal wear due to high cycle rate or length of service. Replace seals as per paragraph above.

Internal Leakage

1. Piston seal leak (by-pass) 1 to 3 cubic inches per minute leakage is considered normal for piston ring construction. Virtually no static leak with lipseal type seals on piston should be expected. Piston seal wear is a usual cause of piston seal leakage. Replace seals as required.
2. With lipseal type piston seals excessive back pressure due to over-adjustment of speed control valves could be a direct cause of rapid seal wear. Contamination in a hydraulic system can result in a scored cylinder bore, resulting in rapid seal wear. In either case, replace piston seals as required.
3. What appears to be piston seal leak, evidenced by the fact that the cylinder drifts, is not always traceable to the piston. To make sure, it is suggested that one side of the cylinder piston be pressurized and the fluid line at the opposite port be disconnected. Observe leakage. If none is evident, seek the cause of cylinder drift in other component parts in the circuit.

Cylinder Fails to Move the Load

1. Pneumatic or hydraulic pressure is too low. Check the pressure at the cylinder to make sure it is to circuit requirements.
2. Piston Seal Leak – Operate the valve to cycle the cylinder and observe fluid flow at valve exhaust ports at end of cylinder stroke. Replace piston seals if flow is excessive.
3. Cylinder is undersized for the load – Replace cylinder with one of a larger bore size.
4. Piston rod broken. Bring the operating conditions of the cylinder to the attention of our engineering department and have our factory repair the cylinder.

Erratic or Chatter Operation

1. Excessive friction at gland or piston bearing due to load misalignment – Correct cylinder-to-load alignment.
2. Cylinder sized too close to load requirements – Reduce load or install larger cylinder.
3. Erratic operation could be traced to the difference between static and kinetic friction. Install speed control valves to provide a back pressure to control the stroke.

Miller MHP Series Metric Hydraulic Cylinders

Ports, Locations
and Piston Speeds

Standard Ports

MHP Series cylinders are supplied with BSPP parallel threaded ports, of a size suitable for normal speed applications – see table opposite. MHP cylinders are also available with a variety of optional ports.

Oversize Ports

For higher speed applications, MHP Series cylinders are available with oversize BSPP or metric ports to the sizes shown in the table opposite, or with extra ports in head or cap faces that are not used for mountings or cushion screws. On 25mm and 32mm bore cylinders, 20mm high port bosses are necessary to provide the full thread length at the cap end – see rod end dimensions for increased height at the head end. Note that Y and PJ dimensions may vary slightly to accommodate oversize ports – please contact the factory where these dimensions are critical.

Port Size and Piston Speed

One of the factors which influences the speed of a hydraulic cylinder is fluid flow in the connecting lines. Due to piston rod displacement, the flow at the cap end port will be greater than that at the head end, at the same piston speed. Fluid velocity in connecting lines should be limited to 5m/s to minimize fluid turbulence, pressure loss and hydraulic shock. The tables opposite are a guide for use when determining whether cylinder ports are adequate for the application. Data shown gives piston speeds for standard and oversize ports and connecting lines where the velocity of the fluid is 5m/s.

If the desired piston speed results in a fluid flow in excess of 5m/s in connecting lines, larger lines with two ports per cap should be considered. Miller Fluid Power recommends that a flow rate of 5m/s in connecting lines should not be exceeded.

Speed Limitations

Where large masses are involved, or piston speeds exceed 0.1m/s and the piston will make a full stroke, cushions are recommended – see cushion information. For cylinders with oversize ports and with a flow exceeding 8m/s into the cap end, a 'non-floating cushion' should be specified. Please consult the factory.

Ports, Air Bleeds and Cushion Adjustment Location

The table below shows standard positions for ports, and cushion adjusting screws where fitted. Air bleeds (see optional features) may be fitted in unoccupied faces of the head or cap, depending on mounting.

Bore ϕ	Standard Cylinder Ports				
	Port Size BSP/G inches	Port Size Metric ¹	Bore of Connecting Lines	Cap End Flow in l/min @ 5m/s	Piston Speed m/s
25	1/4	M14x1.5	7	11.5	0.39
32	1/4	M14x1.5	7	11.5	0.24
40	3/8	M18x1.5	10	23.5	0.31
50	1/2	M22x1.5	13	40	0.34
63	1/2	M22x1.5	13	40	0.21
80	3/4	M27x2	15	53	0.18
100	3/4	M27x2	15	53	0.11
125	1	M33x2	19	85	0.12
160	1	M33x2	19	85	0.07
200	1-1/4	M42x2	24	136	0.07

Bore ϕ	Oversize Cylinder Ports				
	Port Size BSP/G inches	Port Size Metric ¹	Bore of Connecting Lines	Cap End Flow in l/min @ 5m/s	Piston Speed m/s
25	3/8 ²	M18x1.5 ^{2,3}	10	23.5	0.80
32	3/8 ²	M18x1.5 ^{2,3}	10	23.5	0.48
40	1/2	M22x1.5 ³	13	40	0.53
50	3/4	M27x2 ³	15	53	0.45
63	3/4	M27x2 ³	15	53	0.28
80 ⁴	1	M33x2	19	85	0.28
100 ⁴	1	M33x2	19	85	0.18
125 ⁴	1-1/4	M42x2	24	136	0.18
160 ⁴	1-1/4	M42x2	24	136	0.11
200 ⁴	1-1/2	M48x2	30	212	0.11

¹Not to DIN 24 554

²20mm high port bosses fitted at cap end

³ISO 6149 ports are not available on some bore/rod combinations.

⁴Consult factory – not normally available on these bore sizes

Not recommended for 67 mountings at pressures above 100 bar

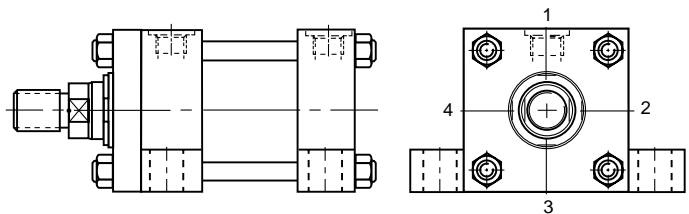

Positions of Ports and Cushion Screws in Head and Cap		Mounting Styles																																		
		53, 52 and 51				67				68				72	90 and 84				94				81				82				89					
Head	Port	1	2	3	4	1	2	3	4	1	2	3	4	1	1	2	3	4	1	2	3	4	1	3	1	2	3	4	1	2	3	4	1	2	3	4
	Cushion	2	3	4	1	3	3	1	1	3	4	1	2	2	2	3	4	1	2	3	4	1	3	1	3	4	1	2	3	4	1	2	3	4	1	2
Cap	Port	1	2	3	4	1	2	3	4	1	2	3	4	1	1	2	3	4	1	2	3	4	1	2	3	4	1	3	1	3	1	2	3	4		
	Cushion	2	3	4	1	3	4	1	2	3	3	1	1	2	2	3	4	1	2	3	4	1	3	4	1	2	3	1	3	1	3	4	1	2		

All dimensions are in millimeters unless otherwise stated.

Miller MHP Series Metric Hydraulic Cylinders

Cylinder Port Options

- Option "S" SAE Straight Thread O-Ring Port. Recommended for most hydraulic applications.
- Option "N" Conventional NPTF Ports (Dry-Seal Pipe Threads). Recommended for pneumatic applications only.
- Option "R" BSPP Port (British Parallel Thread). ISO 228 port commonly used in Europe. See Figure R-G below.
- Option "F" SAE Flange Ports Code 61 (3000 psi). Recommended for hydraulic applications requiring larger port sizes.
- Option "J" BSPT (British Tapered Thread).
- Option "G" Metric Straight Thread Port similar to Option "R" with metric thread. Popular in some European applications. See Figure R-G below.
- Option "M" ISO-6149-1 Metric Straight Thread Port. Recommended for all hydraulic applications designed per ISO standards. See Figure M below.

Bore	"S" SAE	"N" NPTF Pipe Thread	"R" BSPP Parallel Thread (Standard)	"F" SAE 4-Bolt Flange Nom. Size	"J" BSPT Taper Thread	"G" Metric Straight Thread	"M" ISO-6149-1 Metric Straight Thread
25	#6	1/4	1/4	N/A	1/4	M14 x 1.5	M14 x 1.5
32	#6	1/4	1/4	N/A	1/4	M14 x 1.5	M14 x 1.5
40	#6	3/8	3/8	N/A	3/8	M18 x 1.5	M18 x 1.5
50	#10	1/2	1/2	N/A	1/2	M22 x 1.5	M22 x 1.5
63	#10	1/2	1/2	1/2	1/2	M22 x 1.5	M22 x 1.5
80	#12	3/4	3/4	3/4	3/4	M27 x 2	M27 x 2
100	#12	3/4	3/4	3/4	3/4	M27 x 2	M27 x 2
125	#16	1	1	1	1	M33 x 2	M33 x 2
160	#16	1	1	1	1	M33 x 2	M33 x 2
200	#20	1-1/4	1-1/4	1-1/4	1-1/4	M42 x 2	M42 x 2

BSPP Port for MHP Series

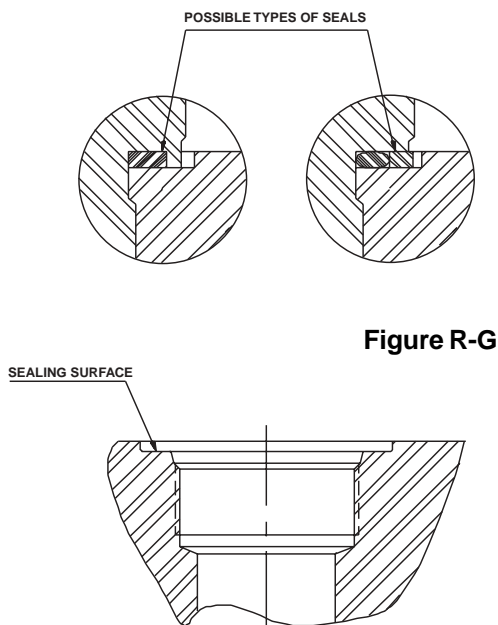

ISO 6149-1 Port for MHP Series

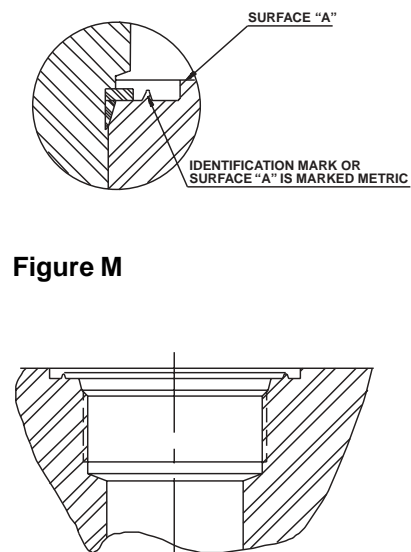

Miller MHP Series Metric Hydraulic Cylinders

Seals and Fluids,
Weights

Seals and Fluid Data

Seal Type	Seal Materials – a combination of:	Fluid Medium to ISO 6743/4-1982	Temperature Range
Standard	Nitrile (NBR), PTFE, enhanced polyurethane (AU)	Mineral oil HH, HL, HLP, HLP-D, HM, HV, MIL-H-5606 oil, air, nitrogen	-20°C to +80°C
Fluoro-carbon	Fluorocarbon elastomer (FPM) Fluorocarbon, PTFE	Fire resistant fluids based on phosphate esters (HFD-R) Also suitable for hydraulic oil at high temperatures/ environments. Not suitable for use with Skydrol. See fluid manufacturer's recommendations.	-20°C to +150°C

Operating Medium

Sealing materials used in the standard cylinder are suitable for use with most petroleum-based hydraulic fluids.

Special seals are available for use with water-glycol or water-in-oil emulsions, and with fluids such as fire-resistant synthetic phosphate ester and phosphate ester-based fluids.

If there is any doubt regarding seal compatibility with the operating medium, please consult the factory.

The table above is a guide to the sealing compounds and operating parameters of the materials used for standard and optional rod bushing, piston and tube seals.

Temperature

Standard seals can be operated at temperatures between -20°C and +80°C. Where operating conditions result in temperatures which exceed these limits, special seal compounds may be required to ensure satisfactory service life – please consult the factory.

Special Seals

Standard seals are fitted (as listed above) to MHP cylinders. For other duties, the optional fluorocarbon seals are available. Special seals, in addition to those shown in the table above, can also be supplied. Please insert a '9' (Modified) in the order code and specify fluid medium when ordering.

Low Friction Seals

For applications where very low friction and an absence of stick-slip are important, the option of low friction seals is available. Please consult the factory.

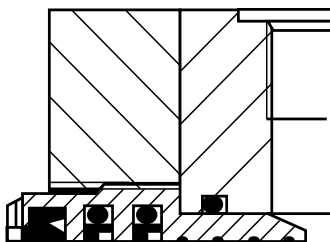

Water Service

Special cylinders are available for use with water as the fluid medium. Modifications include a stainless steel piston rod with lipseal piston, and plating of internal surfaces. When ordering, please specify the maximum operating pressure or load/speed conditions.

Warranty

Miller Fluid Power warrants cylinders modified for use with water or water base fluids to be free of defects in materials and workmanship, but cannot accept responsibility for premature failure caused by corrosion, electrolysis or mineral deposits in the cylinder.

Weights – MHP Series Cylinders

Bore φ	Rod φ	Mounting Styles - Weight at Zero Stroke						Weight per 10mm Stroke kg
		53, 52 51 kg	72 kg	67, 68 kg	90, 84 94 kg	81, 82 kg	89 kg	
25	12	1.2	1.4	1.5	1.4	1.3	1.5	0.05
	18						1.6	0.06
32	14	1.6	1.9	2.0	1.9	1.7	2.0	0.06
	22	1.7						0.08
40	18	3.7	4.0	4.7	4.2	3.9	4.6	0.09
	28	3.8	4.1	4.8	4.3	4.0	4.7	0.12
50	22	5.9	6.5	7.2	7.0	6.3	7.9	0.14
	28	6.0	6.6	7.3	7.1		8.0	0.16
	36				7.2	6.4		0.18
63	28	8.5	9.7	10.1	10.1	8.9	10.6	0.19
	36	8.6	9.8	10.2	10.2	9.0	10.7	0.22
	45	8.7	9.9	10.3	10.4	9.1	10.9	0.27
80	36	16.0	17.3	18.9	19.5	16.5	20.5	0.27
	45	16.1	17.4	19.0	19.6	16.6		0.32
	56	16.3	17.7	19.2	19.8	16.8	20.7	0.39
100	45	22.0	24.0	25.0	28.0	22.7	26.0	0.40
	56			26.0			27.0	0.47
	70	23.0	25.0		29.0	23.2		0.58
125	56	42.0	44.0	48.0	53.0	43.0	48.0	0.65
	70		45.0		54.0		49.0	0.76
	90	43.0		49.0		44.0	50.0	0.95
160	70	69.0	73.0	78.0	90.0	71.0	84.0	1.00
	90				91.0			1.20
	110	70.0	74.0	79.0	92.0	72.0	85.0	1.40
200	90	122.0	129.0	138.0	157.0	127.0	153.0	1.50
	110	123.0	130.0		158.0	128.0		1.80
	140	124.0	131.0	140.0	160.0	129.0	155.0	2.30

All dimensions are in millimeters unless otherwise stated.

Miller MHP Series Metric Hydraulic Cylinders

Air Bleeds

The option of bleed screws is available at either or both ends of the cylinder, at any position except in the port face. The selected positions should be shown in the order code.

Cylinders with bore sizes up to 40mm are fitted with M5 bleed screws; for bore sizes of 50mm and above, M8 bleed screws are fitted. Note that, for cylinders of 50mm bore and above, where it is essential to have the air bleed in the port face, bosses can be welded to the cylinder tube. Please contact the factory for details.

Bushing Drains

The tendency of hydraulic fluid to adhere to the piston rod can result in an accumulation of fluid in the cavity behind the bushing wiperseal under certain operating conditions. This may occur with long stroke cylinders; where there is a constant back pressure as in differential circuitry, or where the ratio of the extend speed to the retract speed is greater than 2 to 1.

A bushing drain port can be provided in the retainer on all Models except 67 – 25, 32 and 40mm bores with standard rod, and Model 81 – 100 to 200mm bores, where it is mounted in the head. Where the bushing is provided in the retainer, the thickness of the retainer is increased by 6mm on 32 and 40mm bore cylinders with max. oversize rod, and by 4mm on 63mm bore cylinders with max. oversize rod. Note that, on model 67 cylinders, drain ports cannot normally be positioned in the same face as ports or cushion valves – please consult the factory.

Bushing drain ports will be the same type as the ports specified on the cylinder assembly except for non 67 mounts on bore sizes 25, 32, 40 and 50 mm. In these cases they will be 1/8 NPTF.

The size of the bushing drain ports are as shown on the adjacent table.

Bushing drains should be piped back to the fluid reservoir, which should be located below the level of the cylinder.

Port Type	Port Size
R (BSPP)	1/8 BSPP
S (SAE)	#4 (SAE)
N (Pipe Thread)	1/8 NPTF
G (Metric Straight)	M10 x 1
M (ISO 6149-1)	M10 x 1
J (BSPT)	1/8 BSPT
F (SAE 4 Bolt Flange)	1/8 BSPP

Stroke Adjusters

Where absolute precision in stroke length is required, a screwed adjustable stop can be supplied. Several types are available – the illustration shows a design suitable for infrequent* adjustment at the uncushioned cap end of a cylinder. Please contact the factory, specifying details of the application and the adjustment required.

Bore φ	D	J	K min	L max
40	M12x1.25	7	75	130
50	M20x1.5	12	75	200
63	M27x2	16	75	230
80	M33x2	20	85	230
100	M42x2	26	70	450
125	M48x2	30	70	500
160	M64x3	40	75	500
200	M80x3	50	80	500

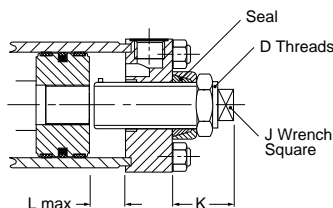

All dimensions are in millimeters unless otherwise stated.

* Infrequent is defined by positioning the retract stroke in a couple of attempts at original machine set-up. The frequent stroke adjuster is recommended when adjustments may be required by the end user.

Spring-Returned, Single-Acting Cylinders

MHP Series single-acting cylinders can be supplied with an internal spring to return the piston after the pressure stroke. Please supply details of load conditions and friction factors, and advise whether the spring is required to advance or return the piston rod.

On spring-returned cylinders, tie rod extensions will be supplied to allow the spring to be 'backed off' until compression is relieved. Tie rod nuts will be welded to the tie rods at the opposite end of the cylinder, to further assure safe disassembly. Please contact the factory when ordering spring-returned cylinders.

Duplex and Tandem Cylinders

A tandem cylinder is made up of two cylinders mounted in line with pistons connected by a common piston rod and rod seals installed between the cylinders to permit double acting operation of each. Tandem cylinders allow increased output force when mounting width or height are restricted.

A duplex cylinder is made up of two cylinders mounted in line with pistons not connected with rod seals installed between the cylinders to permit double acting operation of each. Cylinders may be mounted with piston rod to piston or back to back and are generally used to provide three position operation.

Rod End Bellows

Unprotected piston rod surfaces which are exposed to contaminants with air hardening properties can be protected by rod end bellows. Longer rod extensions are required to accommodate the collapsed length of the bellows. Please consult the factory for further information.

Metallic Rod Wipers

Metallic rod wipers replace the standard wiper seal, and are recommended where dust or splashings might damage the wiper seal material. Metallic rod wipers do not affect cylinder dimensions.

Proximity Sensors

Proximity sensors can be fitted to give reliable end of stroke signals.

Position Feedback

Linear position transducers of various types are available for MHP Series cylinders. Please contact the factory for further details.

Miller MHP Series Metric Hydraulic Cylinders

Replacement Parts
and Service

Service Assemblies and Seal Kits

Service Assembly Kits and Seal Kits for MHP cylinders simplify the ordering and maintenance processes. They contain sub-assemblies which are ready for installation, and are supplied with full instructions. When ordering Service Assemblies and Seal Kits, please refer to the identification plate on the cylinder body, and supply the following information:

Serial Number - Bore - Stroke - Model Number - Fluid Type

Key to Part Numbers

- 1 Head
- 7 Cap
- 14 Bushing
- 15 Cylinder tube
- 17 Piston – Elastomeric
- 18 Cushion plunger
- 19 Tie rod
- 23 Tie rod nut
- 26 Back-up washer (not 25-50mm bore cylinders)

- 73 Floating cushion bushing
- 74 Retaining ring for cushion bushing
- 125 Standard piston seal
- 126 Energizing ring for standard seal 125
- 127 Wear ring for standard piston

¹Not illustrated

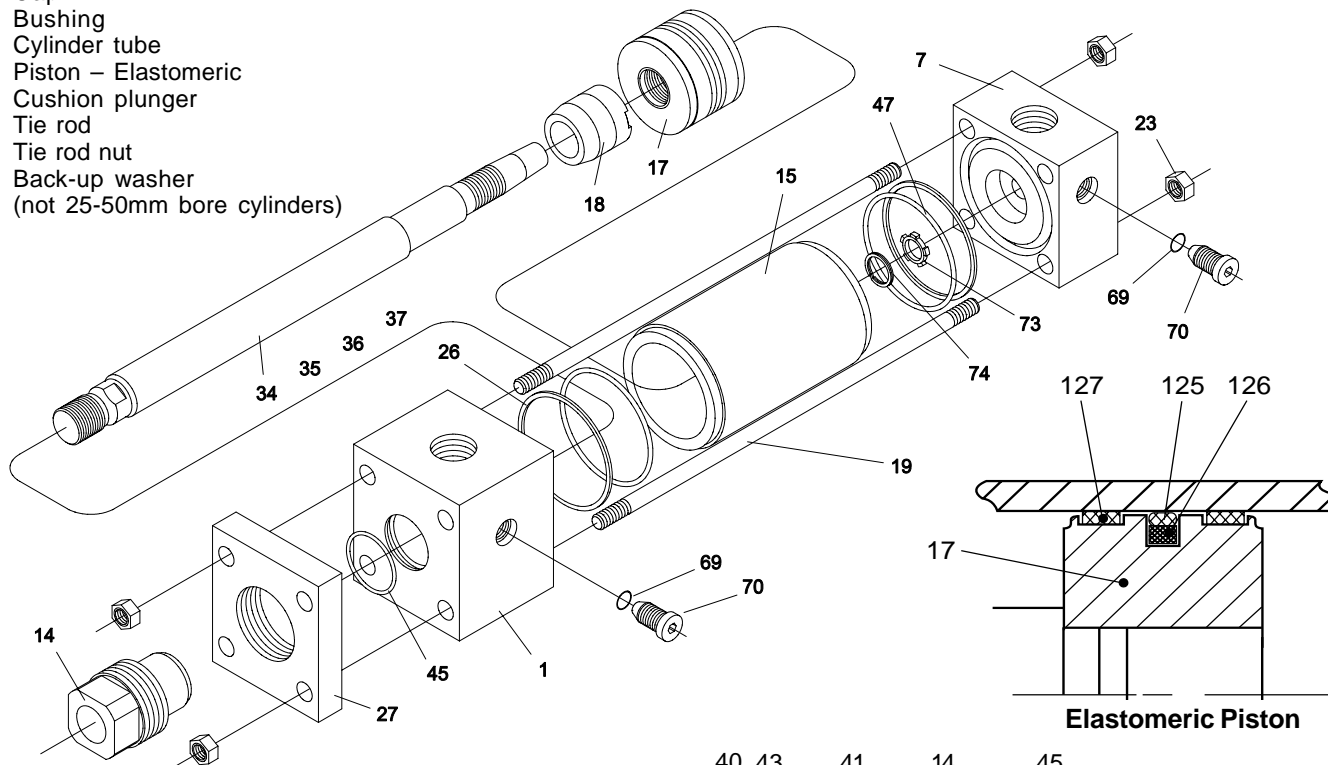

- 27 Retainer
- 34 Piston rod – single rod, no cushion
- 35 Piston rod – single rod, cushion at head end
- 36 Piston rod – single rod, cushion at cap end
- 37 Piston rod – single rod, cushion at both ends
- 40 Wiperseal – for 14
- 41 Lipseal – for 14
- 43 Back-up washer, gland lipseal 41 (not Group 1 seals)
- 45 O-ring – gland/head
- 47 O-ring – cylinder body
- 57¹ Piston rod – double rod, no cushion
- 58¹ Piston rod – double rod, cushion one end
- 60¹ Piston rod – double rod, no cushion
- 61¹ Piston rod – double rod, cushion one end
- 69 O-ring – needle valve and check valve screws
- 70 Needle valve, cushion adjustment

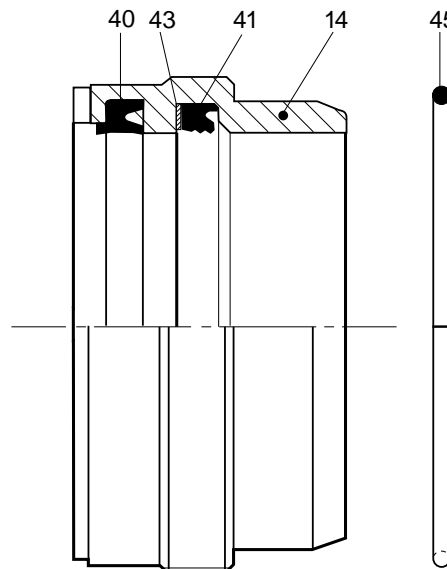

Bushing and Seals

Miller MHP Series Metric Hydraulic Cylinders

Replacement Parts
and Service

Contents and Part Numbers of Seal Kits for Pistons and Bushings

(see key to part numbers opposite)

Bushing Kit – Bushing and Seals* Contain items 14, 40, 41, 43, 45. Where the original bushing incorporates a bushing drain, please consult the factory.

Rod Seal Kit – Bushing Seals* Contain items 40, 41, 43, 45

Miller Series Repair Kit Part Numbers

Rod ø	Bushing Assembly*		Rod Seal Kit*	
	Standard	Fluorocarbon	Standard	Fluorocarbon
12	MHP-KR100-12	MHP-KR200-12	MHP-KR300-12	MHP-KR400-12
14	MHP-KR100-14	MHP-KR200-14	MHP-KR300-14	MHP-KR400-14
18	MHP-KR100-18	MHP-KR200-18	MHP-KR300-18	MHP-KR400-18
22	MHP-KR100-22	MHP-KR200-22	MHP-KR300-22	MHP-KR400-22
28	MHP-KR100-28	MHP-KR200-28	MHP-KR300-28	MHP-KR400-28
36	MHP-KR100-36	MHP-KR200-36	MHP-KR300-36	MHP-KR400-36
45	MHP-KR100-45	MHP-KR200-45	MHP-KR300-45	MHP-KR400-45
56	MHP-KR100-56	MHP-KR200-56	MHP-KR300-56	MHP-KR400-56
70	MHP-KR100-70	MHP-KR200-70	MHP-KR300-70	MHP-KR400-70
90	MHP-KR100-90	MHP-KR200-90	MHP-KR300-90	MHP-KR400-90
110	MHP-KR100-110	MHP-KR200-110	MHP-KR300-110	MHP-KR400-110
140	MHP-KR100-140	MHP-KR200-140	MHP-KR300-140	MHP-KR400-140

Tube Kit – Cylinder Tube End Seals* Contain two each of items 47, 26 (no backup washer on 25-50mm bore).

Piston Kit – Standard Piston Seals* (includes Cylinder Tube End Seals) Contains two each of items 47, 26 (not 25-50mm bore), two of item 127, and one each of items 125, 126.

Rod ø	Tube Seal Kit*		Piston Seal Kit*	
	Standard	Fluorocarbon	Standard	Fluorocarbon
25	MHP-ES100-25	MHP-ES200-25	MHP-KB100-25	MHP-KB200-25
32	MHP-ES100-32	MHP-ES200-32	MHP-KB100-32	MHP-KB200-32
40	MHP-ES100-40	MHP-ES200-40	MHP-KB100-40	MHP-KB200-40
50	MHP-ES100-50	MHP-ES200-50	MHP-KB100-50	MHP-KB200-50
63	MHP-ES100-63	MHP-ES200-63	MHP-KB100-63	MHP-KB200-63
80	MHP-ES100-80	MHP-ES200-80	MHP-KB100-80	MHP-KB200-80
100	MHP-ES100-100	MHP-ES200-100	MHP-KB100-100	MHP-KB200-100
125	MHP-ES100-125	MHP-ES200-125	MHP-KB100-125	MHP-KB200-125
160	MHP-ES100-160	MHP-ES200-160	MHP-KB100-160	MHP-KB200-160
200	MHP-ES100-200	MHP-ES200-200	MHP-KB100-200	MHP-KB200-200

Tie Rod Torques

Bore φ	Tie Rod Torque Nm
25	4.5-5.0
32	7.6-9.0
40	19.0-20.5
50	68-71
63	68-71
80	160-165
100	160-165
125	450-455
160	815-830
200	1140-1155

Repairs

Although MHP cylinders are designed to make on-site maintenance or repairs as easy as possible, some operations can only be carried out in our factory. It is standard policy to fit a cylinder returned to the factory for repair with those replacement parts which are necessary to return it to 'as good as new' condition. Should the condition of the returned cylinder be such that repair would be uneconomical, you will be notified.

Miller MHP Series Metric Hydraulic Cylinders

Model Numbers

How to Order ISO Cylinders

Data Required On All Cylinder Orders

When ordering MHP Series cylinders, be sure to specify each of the following requirements:

(NOTE: – Duplicate cylinders can be ordered by giving the SERIAL NUMBER from the original cylinder. Factory records supply a quick, positive identification.)

a) Series Designation (“MHP”)

b) Mounting Model

Specify your choice of mounting – as shown and dimensioned in this catalog.

c) Seals

d) Piston Rod End Thread Style

Call out thread style letter or specify dimensions. Thread style M will be furnished if not otherwise specified.

e) Cushions (if required)

Specify “Cushion-head end,” “Cushion-cap end” or “Cushion-both ends” as required. If cylinder is to have a double rod and only one cushion is required, be sure to specify clearly which end of the cylinder is to be cushioned.

f) Bore Size

g) Length of Stroke

h) Piston Rod Diameter

Call out rod diameter. In MHP Series cylinders, standard rod diameters will be furnished if not otherwise specified, unless length of stroke makes the application questionable.

i) Ports

BSPP (ISO 228) are standard.

j) Port Locations

k) Modifications

Any modifications that are not identified in the cylinder number shown on the following page should be added to the specifications. These can include special fluids, special seals, air bleeds, double rod cylinders with different rod end styles and diameters. For further information consult factory.

Service Policy

On cylinders returned to the factory for repairs, it is standard policy for Miller Fluid Power to make such part replacements as will put the cylinder in as good as new condition. Should the condition of the returned cylinder be such that expenses for repair would exceed the costs of a new one, you will be notified.

Certified Dimensions

Miller Fluid Power guarantees that all cylinders ordered from this catalog will be built to dimensions shown. All dimensions are certified to be correct, and thus it is not necessary to request certified drawings.

Miller MHP Series Metric Hydraulic Cylinders

How To Order

How to Order – Example: MHP-72BMN-200-0600-090-R11-0

Series	Mounting Style	Bushing	Rod End Style	Cushions **	Bore Dia. mm	Stroke mm	Rod Dia. mm	Port Type	Port Location	Modified
MHP DMHP (D= Double Rod End)	72	B = Externally Removable Bushing	M (Std.) S T X***	R = Rod End Cushioned C = Cap End Cushioned B = Both Ends Cushioned N = Non-Cushioned	-200	-0600	-090	R = BSPP ISO 228 (Standard) M = ISO 6149-1 S = SAE Str. Thd. J = BSPT F = SAE Flange N = NPTF G = Metric Str. Thd.	Head End 1 (Std.) 1 Cap End 2 2 3 3 4 4	0 = Standard 9 = Modified

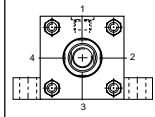

9* The number 9 refers to special options or modifications that deviate from the standard product offering. Non-standard modifications and options not identified in the cylinder model number should be added in the notes when placing an order.

Modifications which can be placed under the designator '9' are as follows:

- Fluorocarbon Seals – for applications that require fire resistant fluids or hydraulic oil at temperatures up to and including 150°C
- Stop Tubing
- Special Port Threads
- Multiple Ports
- Air Bleeds
- Bushing Drain
- Key Retainer
- Special Mounts

Note: The standard #1 port location is at the top of the cylinder, and the standard cushion adjustment screw is in position #2 when facing the rod end of the cylinder. If multiple ports are required, the last number of the part number should be 9, indicating modified and the location of ports desired.

Miller MHP Series Metric Hydraulic Cylinders

Safety Guidelines for Cylinders

Safety Guide for Selecting and Using Hydraulic, Pneumatic Cylinders and Their Accessories

WARNING: ⚠ FAILURE OR IMPROPER SELECTION OR IMPROPER USE OF CYLINDERS AND THEIR RELATED ACCESSORIES CAN CAUSE DEATH, PERSONAL INJURY AND PROPERTY DAMAGE.

Before selecting or using Miller cylinders or related accessories, it is important that you read, understand and follow the following safety information.

User Responsibility

Due to very wide variety of cylinder applications and cylinder operating conditions, The Company does not warrant that any particular cylinder is suitable for any specific application. This safety guide does not analyze all technical parameters that must be considered in selecting a product. The hydraulic and pneumatic cylinders outlined in this catalog are designed to The Company's design guide lines and do not necessarily meet the design guide lines of other agencies such as American Bureau of Shipping, ASME Pressure Vessel Code etc. The user, through its own analysis and testing, is solely responsible for:

- Making the final selection of the cylinders and related accessories.
- Determining if the cylinders are required to meet specific design requirements as required by the Agency(s) or industry standards covering the design of the user's equipment.
- Assuring that the user's requirements are met, OSHA requirements are met, and safety guidelines from the applicable agencies such as but not limited to ANSI are followed and that the use presents no health or safety hazards.
- Providing all appropriate health and safety warnings on the equipment on which the cylinders are used.

Seals

Part of the process of selecting a cylinder is the selection of seal compounds. Before making this selection, consult "How to Select a Miller Cylinder" opposite the "How to Order" page, or contact our engineering department.

The application of cylinders may allow fluids such as cutting fluids, wash down fluids etc. to come in contact with the external area of the cylinder. These fluids may attack the piston rod wiper and or the primary seal and must be taken into account when selecting and specifying seal compounds.

Dynamic seals will wear. The rate of wear will depend on many operating factors. Wear can be rapid if a cylinder is mis-aligned or if the cylinder has been improperly serviced. The user must take seal wear into consideration in the application of cylinders.

Piston Rods

Possible consequences of piston rod failure or separation of the piston rod from the piston include, but are not limited to are:

- Piston rod and or attached load thrown off at high speed.
- High velocity fluid discharge.
- Piston rod extending when pressure is applied in the piston retract mode.

Piston rods or machine members attached to the piston rod may move suddenly and without warning as a consequence of other conditions occurring to the machine such as, but not limited to:

- Unexpected detachment of the machine member from the piston rod.
- Failure of the pressurized fluid delivery system (hoses, fittings, valves, pumps, compressors) which maintain cylinder position.
- Catastrophic cylinder seal failure leading to sudden loss of pressurized fluid.
- Failure of the machine control system.

Following the recommendation of the "Piston Rod Selection Chart and Data" found in this catalog. The suggested piston rod diameter in these charts must be followed in order to avoid piston rod buckling.

Piston rods are not normally designed to absorb bending moments or loads which are perpendicular to the axis of piston rod motion. These additional loads can cause the piston rod to fail. If these types of

additional loads are expected to be imposed on the piston rod, their magnitude should be made known to our engineering department.

The cylinder user should always make sure that the piston rod is securely attached to the machine member.

On occasion cylinders are ordered with double rods (a piston rod extended from both ends of the cylinder). In some cases a stop is threaded on to one of the piston rods and used as an external stroke adjuster. On occasions spacers are attached to the machine member connected to the piston rod and also used as a stroke adjuster. In both cases the stops will create a pinch point and the user should consider appropriate use of guards. If these external stops are not perpendicular to the mating contact surface, or if debris is trapped between the contact surfaces, a bending moment will be placed on the piston rod, which can lead to piston rod failure. An external stop will also negate the effect of cushioning and will subject the piston rod to impact loading. Those two (2) conditions can cause piston rod failure. Internal stroke adjusters are available with and without cushions. The use of external stroke adjusters should be reviewed with our engineering department.

The piston rod to piston and the stud to piston rod threaded connections are secured with an anaerobic adhesive. The strength of the adhesive decreases with increasing temperature. Cylinder which can be exposed to temperatures above +250°F (+121°C) are to be ordered with a non studded piston rod and a pinned piston to rod joint.

Cushions

Cushions should be considered for cylinder applications when the piston velocity is expected to be over 4 inches/second.

Cylinder cushions are normally designed to absorb the energy of a linear applied load. A rotating mass has considerably more energy than the same mass moving in a linear mode. Cushioning for a rotating mass application should be review by our engineering department.

Cylinder Mountings

Some cylinder mounting configurations may have certain limitations such as but not limited to minimum stroke for side or foot mounting cylinders or pressure de-ratings for certain flange mounts. Carefully review the catalog for these types of restrictions.

Always mount cylinders using the largest possible high tensile alloy steel socket head cap screws that can fit in the cylinder mounting holes and torque them to the manufacturer's recommendations for their size.

Port Fittings

Hydraulic cylinders applied with meter out or deceleration circuits are subject to intensified pressure at piston rod end. The rod end pressure is approximately equal to:

$$\frac{\text{operating pressure} \times \text{effective cap end area}}{\text{effective rod end piston area}}$$

Contact your connector supplier for the pressure rating of individual connectors.

Cylinder Modifications or Repairs

Cylinders as shipped from the factory are not to be disassembled and or modified. If cylinders require modifications, these modifications must be done at company locations or by The Company's certified facilities. It is allowed to disassemble cylinders for the purpose of replacing seals or seal assemblies. However, this work must be done by strictly following all the instructions provided with the seal kits.

Miller MHP Series Metric Hydraulic Cylinders

Offer of Sale

Offer of Sale

The items described in this document and other documents or descriptions provided by the Company, its subsidiaries and its authorized distributors are hereby offered for sale at prices to be established by the Company, its subsidiaries and its authorized distributors. This offer and its acceptance by any customer ("Buyer") shall be governed by all of the following Terms and Conditions. Buyer's order for any such item, when communicated to the Company, its subsidiary or an authorized distributor ("Seller") verbally or in writing, shall constitute acceptance of this offer.

1. **Terms and Conditions of Sale:** All descriptions, quotations, proposals, offers, acknowledgments, acceptances and sales of Seller's products are subject to and shall be governed exclusively by the terms and conditions stated herein. Buyer's acceptance of any offer to sell is limited to these terms and conditions. Any terms or conditions in addition to, or inconsistent with those stated herein, proposed by Buyer in any acceptance of an offer by Seller, are hereby objected to. No such additional, different or inconsistent terms and conditions shall become part of the contract between Buyer and Seller unless expressly accepted in writing by Seller. Seller's acceptance of any offer to purchase by Buyer is expressly conditional upon Buyer's assent to all the terms and conditions stated herein, including any terms in addition to, or inconsistent with those contained in Buyer's offer. Acceptance of Seller's products shall in all events constitute such assent.

2. **Payment:** Payment shall be made by Buyer net 30 days from the date of delivery of the items purchased hereunder. Amounts not timely paid shall bear interest at the maximum rate permitted by law for each month or portion thereof that Buyer is late in making payment. Any claims by Buyer for omissions or shortages in a shipment shall be waived unless Seller receives notice thereof within 30 days after Buyer's receipt of the shipment.

3. **Delivery:** Unless otherwise provided on the face hereof, delivery shall be made F.O.B. Seller's plant. Regardless of the method of delivery, however, risk of loss shall pass to Buyer upon Seller's delivery to a carrier. Any delivery dates shown are approximate only and Seller shall have no liability for any delays in delivery.

4. **Warranty:** Seller warrants that the items sold hereunder shall be free from defects in material or workmanship for a period of 18 months from date of shipment from the Company. THIS WARRANTY COMPRISES THE SOLE AND ENTIRE WARRANTY PERTAINING TO ITEMS PROVIDED HEREUNDER. SELLER MAKES NO OTHER WARRANTY, GUARANTEE, OR REPRESENTATION OF ANY KIND WHATSOEVER. ALL OTHER WARRANTIES, INCLUDING BUT NOT LIMITED TO, MERCHANTABILITY AND FITNESS FOR PURPOSE, WHETHER EXPRESS, IMPLIED, OR ARISING BY OPERATION OF LAW, TRADE USAGE, OR COURSE OF DEALING ARE HEREBY DISCLAIMED.

NOTWITHSTANDING THE FOREGOING, THERE ARE NO WARRANTIES WHATSOEVER ON ITEMS BUILT OR ACQUIRED WHOLLY OR PARTIALLY, TO BUYER'S DESIGNS OR SPECIFICATIONS.

5. **Limitation of Remedy:** SELLER'S LIABILITY ARISING FROM OR IN ANY WAY CONNECTED WITH THE ITEMS SOLD OR THIS CONTRACT SHALL BE LIMITED EXCLUSIVELY TO REPAIR OR REPLACEMENT OF THE ITEMS SOLD OR REFUND OF THE PURCHASE PRICE PAID BY BUYER, AT SELLER'S SOLE OPTION. IN NO EVENT SHALL SELLER BE LIABLE FOR ANY INCIDENTAL, CONSEQUENTIAL OR SPECIAL DAMAGES OF ANY KIND OR NATURE WHATSOEVER, INCLUDING BUT NOT LIMITED TO LOST PROFITS ARISING FROM OR IN ANY WAY CONNECTED WITH THIS AGREEMENT OR ITEMS SOLD HEREUNDER, WHETHER ALLEGED TO ARISE FROM BREACH OF CONTRACT, EXPRESS OR IMPLIED WARRANTY, OR IN TORT, INCLUDING WITHOUT LIMITATION, NEGLIGENCE, FAILURE TO WARN OR STRICT LIABILITY.

6. **Changes, Reschedules and Cancellations:** Buyer may request to modify the designs or specifications for the items sold hereunder as well as the quantities and delivery dates thereof, or may request to cancel all or part of this order, however, no such requested modification or cancellation shall become part of the contract between Buyer and Seller unless accepted by Seller in a written amendment to this Agreement. Acceptance of any such requested modification or cancellation shall be at Seller's discretion, and shall be upon such terms and conditions as Seller may require.

7. **Special Tooling:** A tooling charge may be imposed for any special tooling, including without limitation, dies, fixtures, molds and patterns, acquired to manufacture items sold pursuant to this contract. Such special tooling shall be and remain Seller's property notwithstanding payment of any charges by Buyer.

In no event will Buyer acquire any interest in apparatus belonging to Seller which is utilized in the manufacture of the items sold hereunder, even if such apparatus has been specially converted or adapted for such manufacture and notwithstanding any charges paid by Buyer. Unless otherwise agreed, Seller shall have the right to alter, discard or otherwise dispose of any special tooling or other property in its sole discretion at any time.

8. **Buyer's Property:** Any designs, tools, patterns, materials, drawings, confidential information or equipment furnished by Buyer, or any other items which become Buyer's property, may be considered obsolete and may be destroyed by Seller after two (2) consecutive years have elapsed without Buyer placing an order for the items which are manufactured using such property. Seller shall not be responsible for any loss or damage to such property while it is in Seller's possession or control.

9. **Taxes:** Unless otherwise indicated on the face hereof, all prices and charges are exclusive of excise, sales, use, property, occupational or like taxes which may be imposed by any taxing authority upon the manufacture, sale or delivery of the items sold hereunder. If any such taxes must be paid by Seller or if Seller is liable for the collection of such tax, the amount thereof shall be in addition to the amounts for the items sold. Buyer agrees to pay all such taxes or to reimburse Seller therefore upon receipt of its invoice. If Buyer claims exemption from any sales, use or other tax imposed by any taxing authority, Buyer shall save Seller harmless from and against any such tax, together with any interest or penalties thereon which may be assessed if the items are held to be taxable.

10. **Indemnity for Infringement of Intellectual Property Rights:** Seller shall have no liability for infringement of any patents, trademarks, copyrights, trade dress, trade secrets or similar rights except as provided in this Part 10. Seller will defend and indemnify Buyer against allegations of infringement of U.S. patents, U.S. trademarks, copyrights, trade dress and trade secrets (hereinafter "Intellectual Property Rights"). Seller will defend at its expense and will pay the cost of any settlement or damages awarded in an action brought against Buyer based on an allegation that an item sold pursuant to this contract infringes the Intellectual Property Rights of a third party. Seller's obligation to defend and indemnify Buyer is contingent on Buyer notifying Seller within ten (10) days after Buyer becomes aware of such allegations of infringement, and Seller having sole control over the defense of any allegations or actions including all negotiations for settlement or compromise. If an item sold hereunder is subject to a claim that it infringes the Intellectual Property Rights of a third party, Seller may, at its sole expense and option, procure for Buyer the right to continue using said item, replace or modify said item so as to make it noninfringing, or offer to accept return of said item and return the purchase price less a reasonable allowance for depreciation. Notwithstanding the foregoing, Seller shall have no liability for claims of infringement based on information provided by Buyer, or directed to items delivered hereunder for which the designs are specified in whole or part by Buyer, or infringements resulting from the modification, combination or use in a system of any item sold hereunder. The foregoing provisions of this Part 10 shall constitute Seller's sole and exclusive liability and Buyer's sole and exclusive remedy for infringement of Intellectual Property Rights.

If a claim is based on information provided by Buyer or if the design for an item delivered hereunder is specified in whole or in part by Buyer, Buyer shall defend and indemnify Seller for all costs, expenses or judgments resulting from any claim that such item infringes any patent, trademark, copyright, trade dress, trade secret or any similar right.

11. **Force Majeure:** Seller does not assume the risk of and shall not be liable for delay or failure to perform any of Seller's obligations by reason of circumstances beyond the reasonable control of Seller (hereinafter "Events of Force Majeure"). Events of Force Majeure shall include without limitation, accidents, acts of God, strikes or labor disputes, acts, laws, rules or regulations of any government or government agency, fires, floods, delays or failures in delivery of carriers or suppliers, shortages of materials and any other cause beyond Seller's control.

12. **Entire Agreement/Governing Law:** The terms and conditions set forth herein, together with any amendments, modifications and any different terms or conditions expressly accepted by Seller in writing, shall constitute the entire Agreement concerning the items sold, and there are no oral or other representations or agreements which pertain thereto. This Agreement shall be governed in all respects by the law of the State of Ohio. No actions arising out of the sale of the items sold hereunder or this Agreement may be brought by either party more than two (2) years after the cause of action accrues.

Miller Fluid Power

Main Plant

800 North York Road

Bensenville, IL 60106

(630) 766-3400—Local

(800) 323-2520—Elsewhere

(630) 350-0294—FAX

Miller Fluid Power

Mississauga Office

1214 Kamato Road

Mississauga, Ontario

L4W 1Y1

(905) 625-2781 – Voice

(905) 624-8724 – FAX

All specifications and information subject to
change without notice or prior obligation.

Catalog M1151

05/02

